

arca®

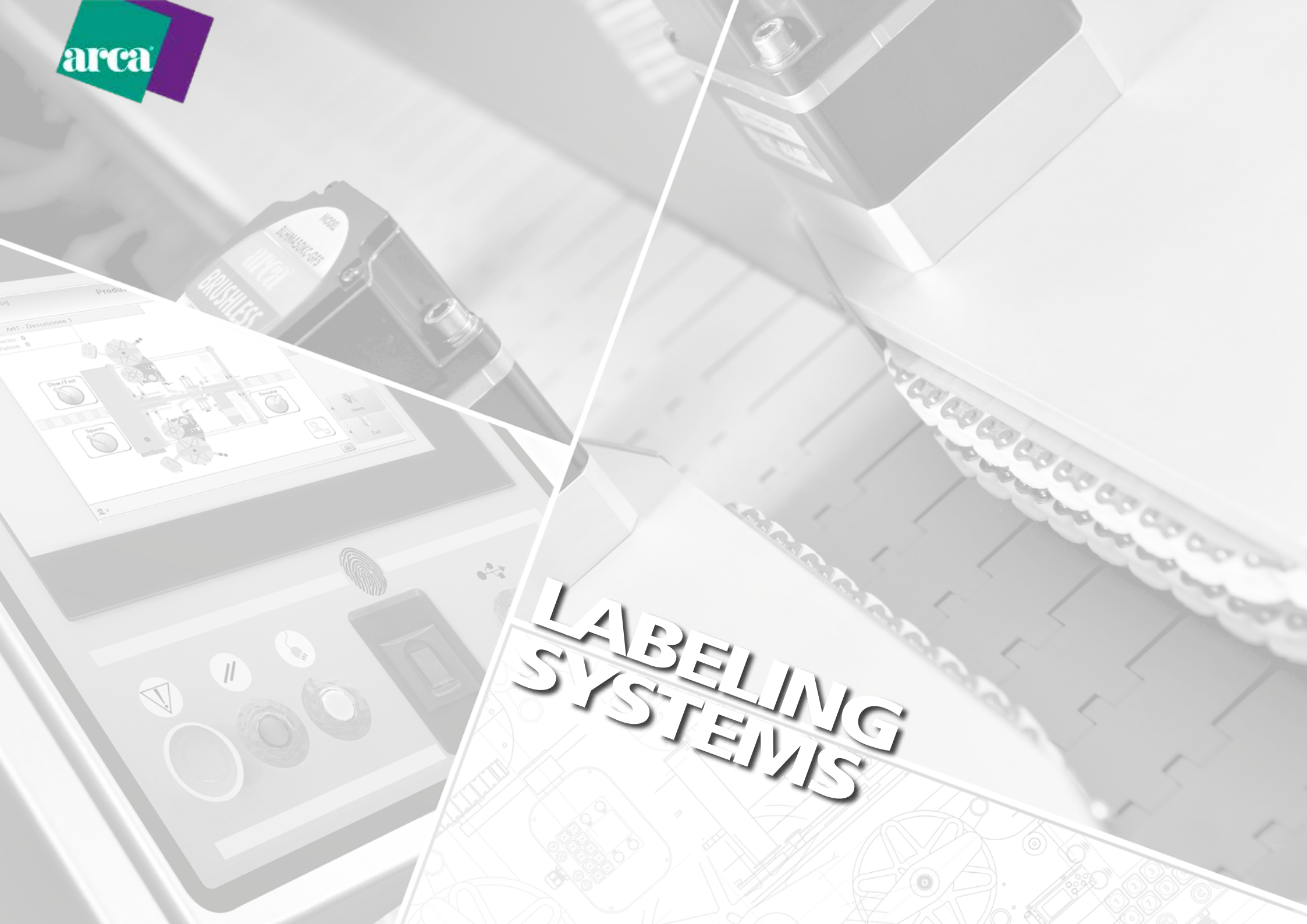

LABELING SYSTEMS





LABELING SYSTEMS

*“Linear” labeling systems that guarantee all the flexibility of the self adhesive market.
No glue to feed in, heat or clean up.
Above all very quick “set up”, without the need for the replacement of mechanical parts
(format changes) typical of rotary handling*

Sistemi di etichettatura “lineari” che garantiscono tutta la flessibilità dell’autoadesivo.
Niente colla da alimentare, scaldare, pulire.
E soprattutto, “set up” rapidissimi, senza necessità di sostituzione di parti meccaniche (cambi formato), tipica delle movimentazioni rotative

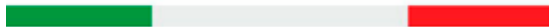

M A D E I N I T A L Y

OPEN FRAME & ARCA CLIP	p. 4
<i>CRAZY FOR STEEL</i>	p. 4
ONE SIDE ADJUSTMENTS	p. 4
BRUSHLESS MOTORS	p. 5
ELECTRICAL EXCELLENCE	p. 5
ADVANCED CONTROL LOGIC	p. 6
MORE SAFETY	p. 7
ATTENTION FOR DETAILS	p. 8
GLOBAL SERVICE	p. 10
LIGHT SERIES	p. 12
WRAP AROUND UP	p. 14
SIDE	p. 16
TOP	p. 18
FRONT SIDE	p. 24
FRONT TOP BASE (<i>c-wrapping</i>)	p. 26
WRAP AROUND DOWN	p. 28
WRAP AROUND DOWN (<i>INDEXED</i>)	p. 32
TOP&BASE	p. 34
SOLID SERIES	p. 36
DIGITAL MMI	p. 38
GRAPHIC MMI 4.0	p. 39
SKYTECH & SLIDING DOOR PROTECTION	p. 40
SKYTECH LOW LEVEL	p. 41
NON STOP	p. 42
WRAP AROUND UP	p. 44
WRAP AROUND UP (<i>INDEXED</i>)	p. 50
WRAP AROUND UP (<i>CONICAL</i>)	p. 54
SIDE	p. 56
SIDE TOP	p. 57

SIDE BACK	p. 58
TOP	p. 59
TOP SIDE (<i>SEAL</i>)	p. 60
BASE	p. 62
FRONT SIDE	p. 64
FRONT TWO SIDES (<i>C-WRAPPING</i>)	p. 65
WRAP AROUND DOWN	p. 66
TWO SIDES	p. 68
FRONT R & TOP (<i>ROTATING</i>)	p. 88
TOP & BASE	p. 90
SIDE & WRAP DOWN (<i>INDEXED</i>) TWO	p. 94
SIDES & TOP	p. 96
TWO SIDES & SIDE TOP	p. 98
COMBI	p. 102
SPECIAL CONVEYORS	p. 108
SEAL ADAPTERS	p. 110
SPECIAL BASES	p. 112
OTHER DEVICES	p. 114
SPECIALIZED LABELING SYSTEMS	p. 116
SEAL/TOP/BASE 110 SEMI-AUTOMATIC	p. 118
WRAP AROUND 160 SEMI-AUTOMATIC	p. 120
STRIPED LINERLESS 5000	p. 122
CONVERTER	p. 130
FEEDER	p. 132
CARD BOARD	p. 134
PHARMA SEAL 4.0	p. 140

1

The innovative structure of Arca systems. Main bases in square sectioned steel tubing, without paneling. In order to exploit every inch of space, to be able to see, clean, wash and operate without impediment, thanks to the utmost accessibility. With the ARCA CLIP it's really simple to add or take away components and accessories, change labelers and disassemble parts for repair or servicing; without drilling, without welding and with limited working time and costs

OPEN FRAME

L'innovativa struttura dei sistemi Arca. Basamenti in tubolare d'acciaio a sezione quadrata, senza pannellature. Per sfruttare ogni centimetro di spazio, per vedere, per pulire e lavare, per operare senza impedimenti grazie alla massima accessibilità. Con ARCA CLIP è semplicissimo aggiungere o levare componenti ed accessori, cambiare le etichettatrici, smontare parti da riparare o revisionare; senza forare, senza saldare, con tempi e costi di intervento contenuti



2

The main bases, stanchions, conveyors and electric installation cabinets are made entirely in steel to guarantee the utmost solidness. No vibrations, no bending. Precise and indestructible systems, intended to last a lifetime. AISI304 stainless steel main bases with shot blasted finish (STEEL) or construction grade steel main bases with metallic grey non scratch epoxy powder finish (IRON). Conveyors, paneling and electric cabinets made of AISI304 stainless steel, with matt finish

CRAZY FOR STEEL

Basamenti, montanti, convogliatori e armadi degli impianti elettrici, sono interamente realizzati in acciaio per garantire la massima solidità. Nessuna vibrazione, nessuna flessione. Sistemi precisi e indistruttibili, destinati a durare una vita. Basamenti in acciaio inossidabile AISI304 con finitura STEEL micropallinata oppure in acciaio da costruzione con finitura IRON antigraffio a polvere epossidica di colore grigio metallizzato. Convogliatori, pannellature e armadi elettrici in acciaio inossidabile AISI304 con finitura satinata



Arca do not use extruded aluminium bars for the main bases of their systems

Arca non impiega profilati in alluminio estruso, per i basamenti dei propri sistemi

3

ONE SIDE adjustment: it allows for working on a single handwheel and from either side of the system. Format changes are quick and guided by numerical references. All the adjustments are unequivocally identified with alphanumeric acronyms, retraceable to "format change" tables

ONE SIDE ADJUSTMENTS

Regolazione ONE SIDE: consente di agire su un solo volantino e da uno qualsiasi dei lati del sistema. I cambi formato sono veloci e guidati da riferimenti numerici. Tutte le regolazioni sono identificate univocamente con sigle alfanumeriche, riconducibili alle tabelle di "cambio formato"

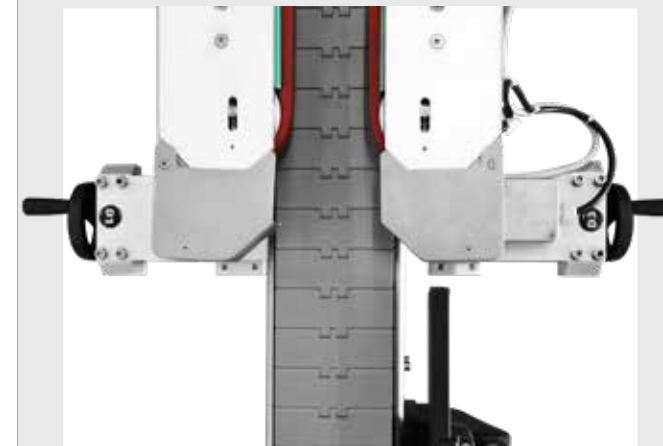

4

- No mechanically derived movement, reducing wear and noise, improving precision*
Product handling devices controlled by brushless motors; effective, practical and safe:
- constant power thrust at any speed
 - no breaches, nor oil leakage
 - easy to clean
 - suitable even at high room temperatures (50°)
 - longer average life cycle and zero maintenance
 - no risk of burns ("cold" motors)

BRUSHLESS MOTORS

- Nessuna movimentazione derivata meccanicamente; più precisione, meno usura e rumore
 Dispositivi di manipolazione prodotti controllati da motori brushless; efficaci, pratici e sicuri:
- coppia di potenza costante a qualsiasi velocità
 - nessun trafilamento, né perdita d'olio
 - facilmente pulibili
 - idonei anche alle alte temperature ambiente (50°)
 - vita media più lunga e zero manutenzione
 - non presentano rischi di ustione (motori "freddi")



- licence free non proprietary electronics; readily available "off the shelf", from anywhere
- shielded cables and metal cable blocks with IP68 grade isolation
- power circuits protected by automatic switch with the possibility for link to alarms (e.g. component on overcharge)
- containment cabinets (with compulsory ventilation) correctly sized, easily accessible and made in steel for protection against knocks and electromagnetic interference
- compliance with Electromagnetic Compatibility Guidelines (EMC 2014/30/CE) and Low Tension (LVD 2014/35/CE)

5

ELECTRICAL EXCELLENCE

- componenti elettronici "non proprietari"; disponibili "off the shelf", ovunque nel mondo
- fili elettrici schermati e pressacavi metallici grado di tenuta IP68
- circuiti di potenza protetti da interruttore automatico con possibilità di derivazione allarmi (es: componente in sovraccarico)
- armadi di contenimento (a ventilazione forzata) correttamente dimensionati, facilmente accessibili e realizzati in acciaio per la protezione dagli urti e dalle perturbazioni elettromagnetiche
- conformità alle direttive Compatibilità Elettromagnetica (EMC 2014/30/CE) e Bassa Tensione (LVD 2014/35/CE)

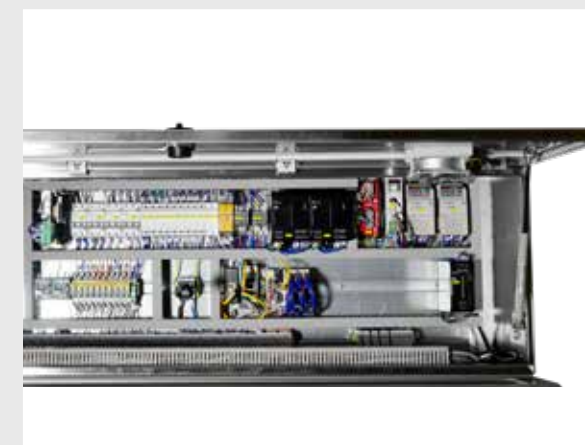

Intuitive interfaces with the most advanced features:

- **SYNCROSPEED:** operating speeds for all product handling devices (spacers, aligners, lateral and upper stabilizers, wrapping units and adapters) can be automatically synchronized to the “master” speed set for the conveyor
- *on-the-fly adjustments, instantaneous and accurate*
- *alarm management is carried out according to “positive logic”. The detection of good results from all the checks, rather than of anomalies, also ensures against breakdown of the control device*
- **QUICK SETUP** using “product programs” that memorize and recall operating settings
- *ability to Ethernet interface to connect to the enterprise operating system*

ADVANCED CONTROL LOGIC

Interfacce intuitive con le funzioni più avanzate:

- **SYNCROSPEED:** le velocità di tutti i dispositivi di movimentazione del prodotto (distanziatori, orientatori, stabilizzatori superiori e laterali, rotolatori, adattatori), possono essere automaticamente sincronizzate alla velocità “master” impostata per il convogliatore
- regolazioni “al volo”, istantanee ed accurate
- la gestione degli allarmi è effettuata secondo logica “positiva”. La rilevazione del buon esito di tutte le verifiche, invece che dell’anomalia, garantisce anche dal guasto del dispositivo di controllo
- **QUICK SETUP** per l’avviamento rapido, mediante “programmi prodotto” che consentono la memorizzazione e il richiamo dei dati necessari al funzionamento
- possibilità di interfaccia Ethernet per la connessione al sistema operativo aziendale

The analogic controls (for the simplest systems) are identified with explicit and intuitive icons that overcome any language barriers

I comandi analogici (per i sistemi più semplici) sono identificati con icone chiare ed intuitive che superano ogni barriera linguistica



Color touch screen MMI
MMI, touch screen a colori

4.0 industry



The most advanced systems are equipped with a colour touch screen interface with synoptic panel. CFR 21 Part 11 compliant, with biometric access control and complete with the most advanced functionality

I sistemi più avanzati sono dotati di interfaccia touch screen a colori, con quadro sinottico. Conforme CFR 21 Part 11, con controllo accessi biometrico e completa delle funzionalità più avanzate

7

Safety for the operators as for maintenance technicians:

- *in the labelers the rotating disks and spindles have no holes or dangerous openings*
- *dangerous points are covered and any gaps are always of less than 4mm*
- *the traction units of the labelling machines open and close without the operator touching the danger points*
- *thanks to the "local protection", Arca systems ensure the easiest working. "Local" accident proof*
- *protection devices safeguard also the completeness of the system and products, in the event of erroneous settings*

MORE SAFETY

Sicurezza per gli operatori come per i manutentori:

- *nelle etichettatrici i dischi e i mandrini in rotazione non presentano fori, né aperture pericolose*
- *i punti pericolosi sono protetti e gli eventuali interstizi sono sempre inferiori a 4 mm*
- *i gruppi di trazione delle etichettatrici si aprono e si chiudono senza che l'operatore tocchi i punti pericolosi*
- *grazie alle "protezioni localizzate", i sistemi Arca garantiscono la più agevole operatività*
- *i dispositivi di protezione salvaguardano anche l'integrità del sistema e dei prodotti, in caso di regolazioni errate*



No detail is left to chance:

- *product guides, made in non scratch white polythene with very smooth sliding*
- *spirit level for easier positioning of the system*
- *wires and cables are fed inside the metal structure*
- *working level height adjustable at the installation stage*
- *acoustic/LED lamp luminous signals, longer lasting and with more intense colors. Color code logic conforming with the EN60204 standard*

ATTENTION FOR DETAILS

Nessun dettaglio è lasciato al caso:

- *guide prodotto, realizzate in polizene bianco antigraffio, ad alto scorrimento*
 - *livella a bolla d'aria per un più agevole posizionamento del sistema*
 - *fili e cavi sono condotti all'interno della struttura metallica*
 - *piano di lavoro regolabile in altezza in fase di installazione*
 - *segnalatori acustici/luminosi con lampade a Led, per una maggior durata e colori più intensi.*
- Logica di impiego dei colori conforme alla norma EN60204





An exceptional product is not enough! The related services are the key-point of its value: interactive and customized spare parts catalogs for each unit, FAT and SAT validations, training and continuous assistance to obtain the maximum from Arca products. They are available from distance and at customer's site, worldwide!

GLOBAL SERVICE

Un prodotto eccezionale non basta! I servizi correlati sono una parte fondamentale del valore: manuali di istruzione all'uso, cataloghi ricambi interattivi e personalizzati per ciascuna unità, validazioni FAT e SAT, training e assistenza continua per ottenere il massimo dai prodotti Arca; sia da remoto, sia presso la nostra sede o quella del cliente ovunque nel mondo!

	FACTORY ACCEPTANCE TEST (FAT) LABELLING SYSTEM Mod. Pharma seal 4.0	Doc. n°: FAT01-4002-PHS Page 1 of 48
FACTORY ACCEPTANCE TEST LABELLING SYSTEM Mod. Pharma seal 4.0		
	SITE ACCEPTANCE TEST (SAT) LABELLING SYSTEM Mod. Pharma seal 4.0	Doc. n°: SAT01-4002-HS Page 1 of 39
SITE ACCEPTANCE TEST LABELLING SYSTEM Mod. Pharma Seal 4.0		
APPROVAL BEFORE EXECUTION		
Written by	Fabio Tunesi Arca Project Manager	13/03/2020 Date
Review by	Fabio Tunesi Arca Project Manager	13/03/2020 Date
Checked by	Luca Morani Arca After Sales Manager	13/03/2020 Date
Approved by	Customer	
Written by	Fabio Tunesi Arca Project Manager	13/03/2020 Date
Review by	Fabio Tunesi Arca Project Manager	13/03/2020 Date
	Luca Morani	13/03/2020 Date

Etichettatrice
Serie - S
Modello - Sharp 4.0

Istruzioni originali

3.1. Inserimento di un valore tramite tastierino

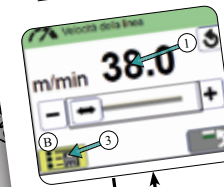

1. Premere sul valore numerico per digitare il valore.
2. Viene visualizzata una nuova finestra per l'inserimento del dato. Confermare il valore inserito premendo il tasto "A". In alto a destra vengono visualizzati i valori massimo e minimo impostabili per il parametro.
3. Premere sul pulsante "B" se si vuole salvare il dato nella configurazione del programma etichettatura in uso.

4. Funzione Jog

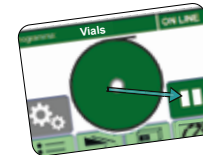

L'unità di controllo dispone di una funzione Jog per poter effettuare dei singoli cicli di erogazione al fine di testare le impostazioni dell'etichettatrice.
La funzione Jog è disponibile solo con l'etichettatrice in modalità OFF LINE.

Accurate and exhaustive instruction manuals are available on USB pen drive, inclusive of electrical/pneumatic diagrams and interactive software to identify spare parts

Manuali d'istruzione su USB. Accurati, completi di schemi elettrici/pneumatici e programma interattivo per l'identificazione dei ricambi

Pre-Delivery Inspection, FAT and SAT validation procedures, especially oriented to the pharmaceutical world (Pharma Documentation Pack)

Pre Delivery Inspection e procedure di validazione F.A.T. e S.A.T., soprattutto rivolte al mondo farmaceutico (Pharma Documentation Pack)



Assistance by phone for "troubleshooting" with diagnostics from distance (on 4.0 models). With Arca Care call whenever you want!

Assistenza telefonica per il "trouble shooting" con diagnostica da remoto (modelli 4.0). Con Arca Care chiama quando vuoi!

Video training, FAT, SAT assistance and installation carried out by remote to avoid costs and travel times

Video training, FAT, assistenza SAT e installazione effettuati da remoto per azzerare costi e tempi di trasferta



Technical interventions everywhere! Arca installs and maintains directly in every part of the world. In addition, it has a consolidated distribution network in over 60 countries, to also guarantee local assistance

Interventi tecnici ovunque! Arca installa e manutiene direttamente in ogni parte del mondo. Inoltre, dispone di una consolidata rete distributiva in oltre 60 paesi, per garantire anche un'assistenza locale

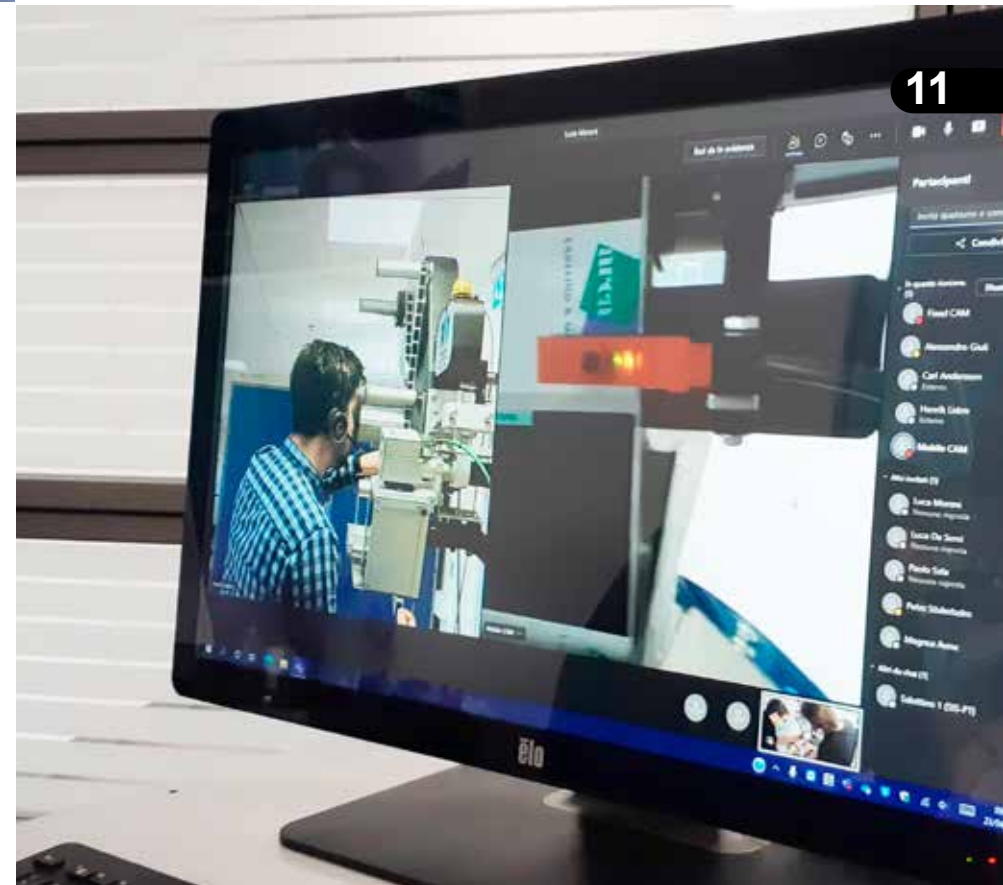

*Minimum space, maximum efficiency.
All the reliability of the most simple solutions,
without jeopardizing quality*

1 or 2
TOP&BASE

Light Series

*Minimo ingombro, massima efficienza.
Tutta l'affidabilità delle soluzioni più semplici,
senza compromessi con la qualità*

Labelers

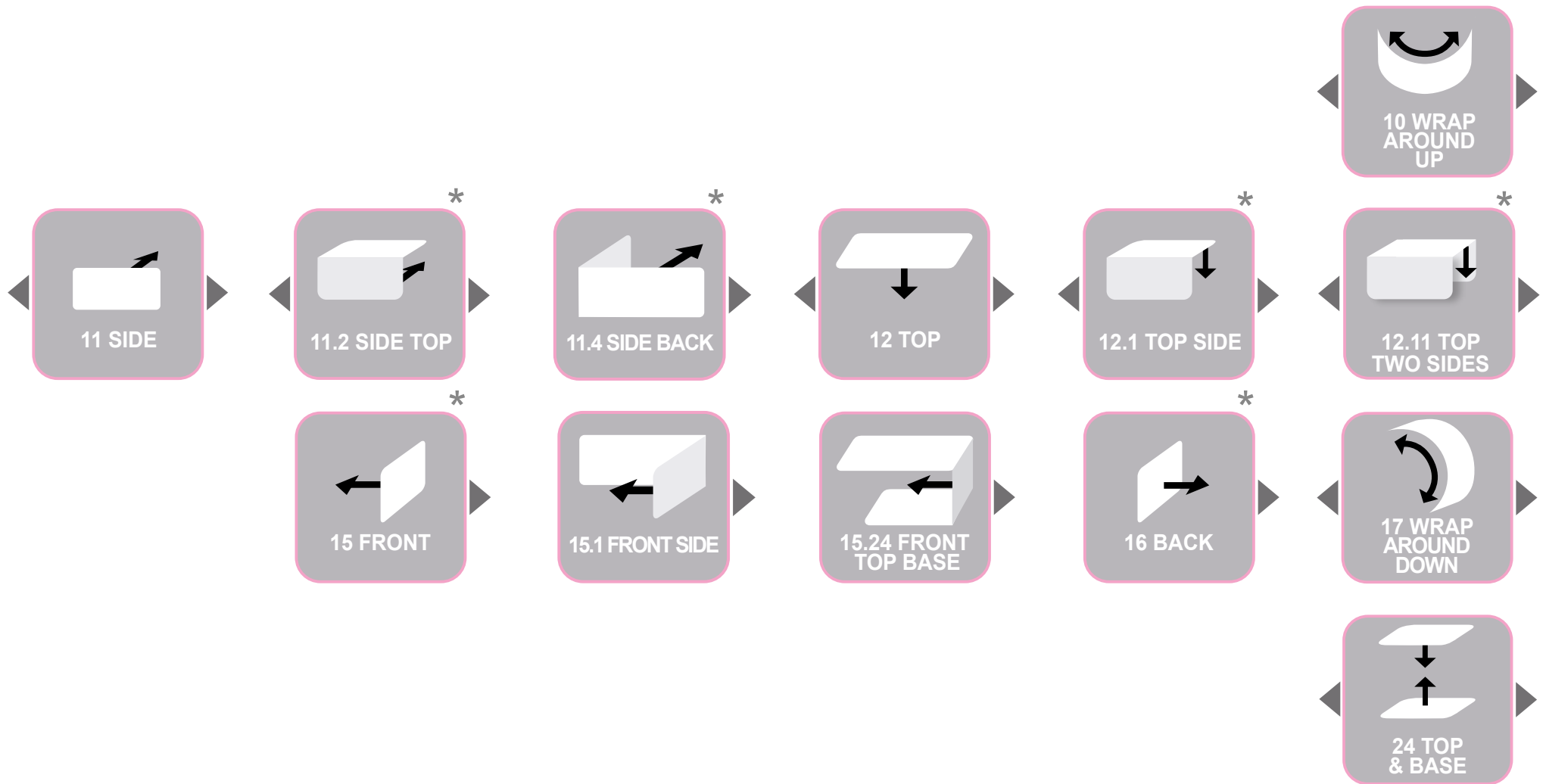



WRAP AROUND UP

Light

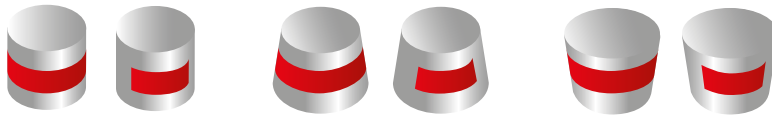

In the Light series, the Vertical Up application is realized with the labeler positioned on the side opposite the operator side (control panel). The limit is irrelevant in "out of line" systems, being accessible from both sides anyway. Is still available a remotable control unit. It allows to operate from a unique system side

Nella serie Light, l'applicazione Wrapping Up è realizzata con l'etichettatrice posizionata sul lato opposto al lato operatore (pannello di controllo). Il limite è irrilevante nei sistemi "fuori linea", essendo comunque accessibili da entrambi i lati. È comunque disponibile un'unità di controllo remotabile che consente di operare da un solo lato del sistema

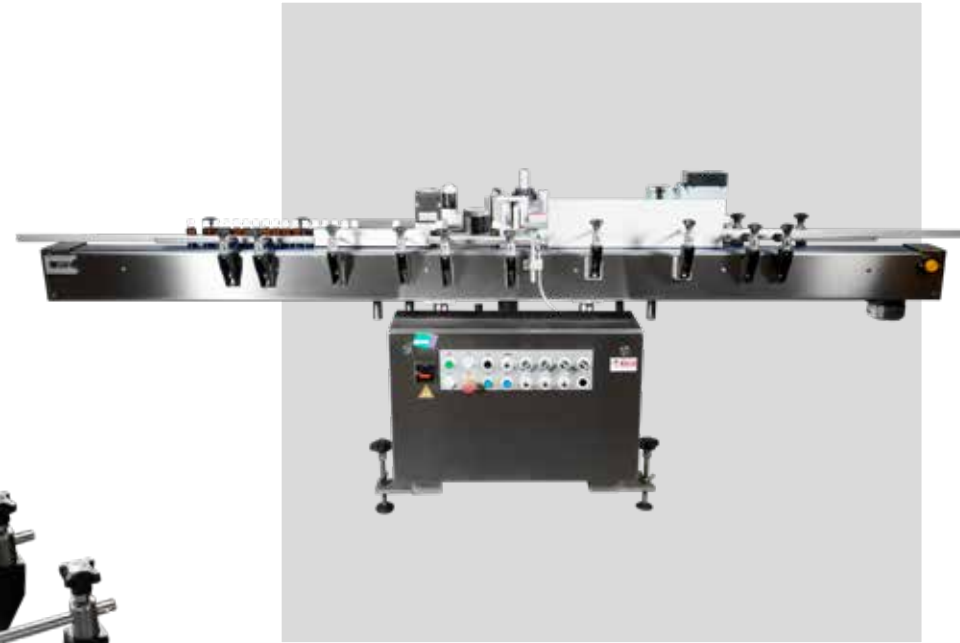
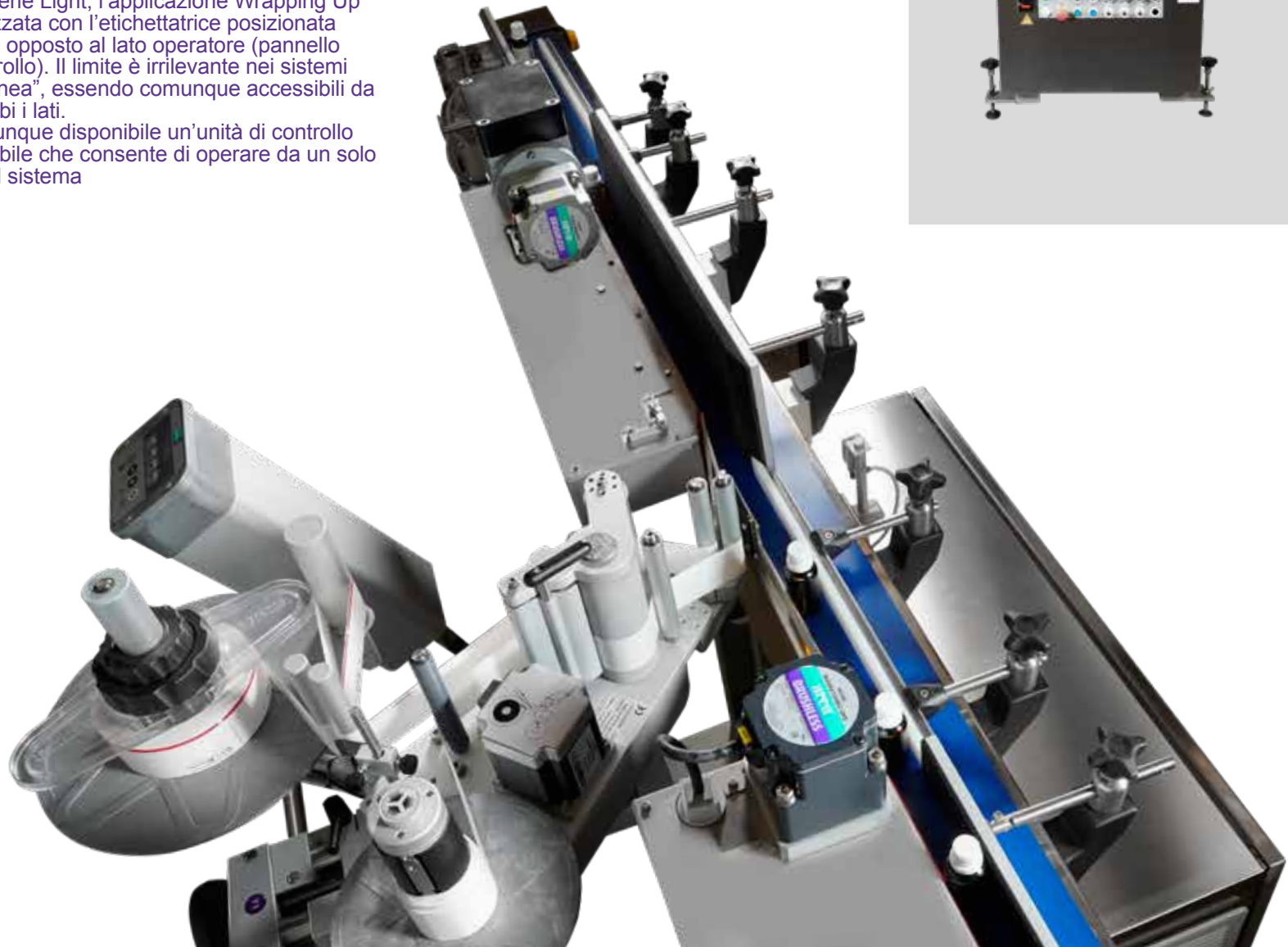



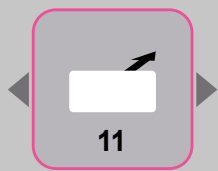

SIDE

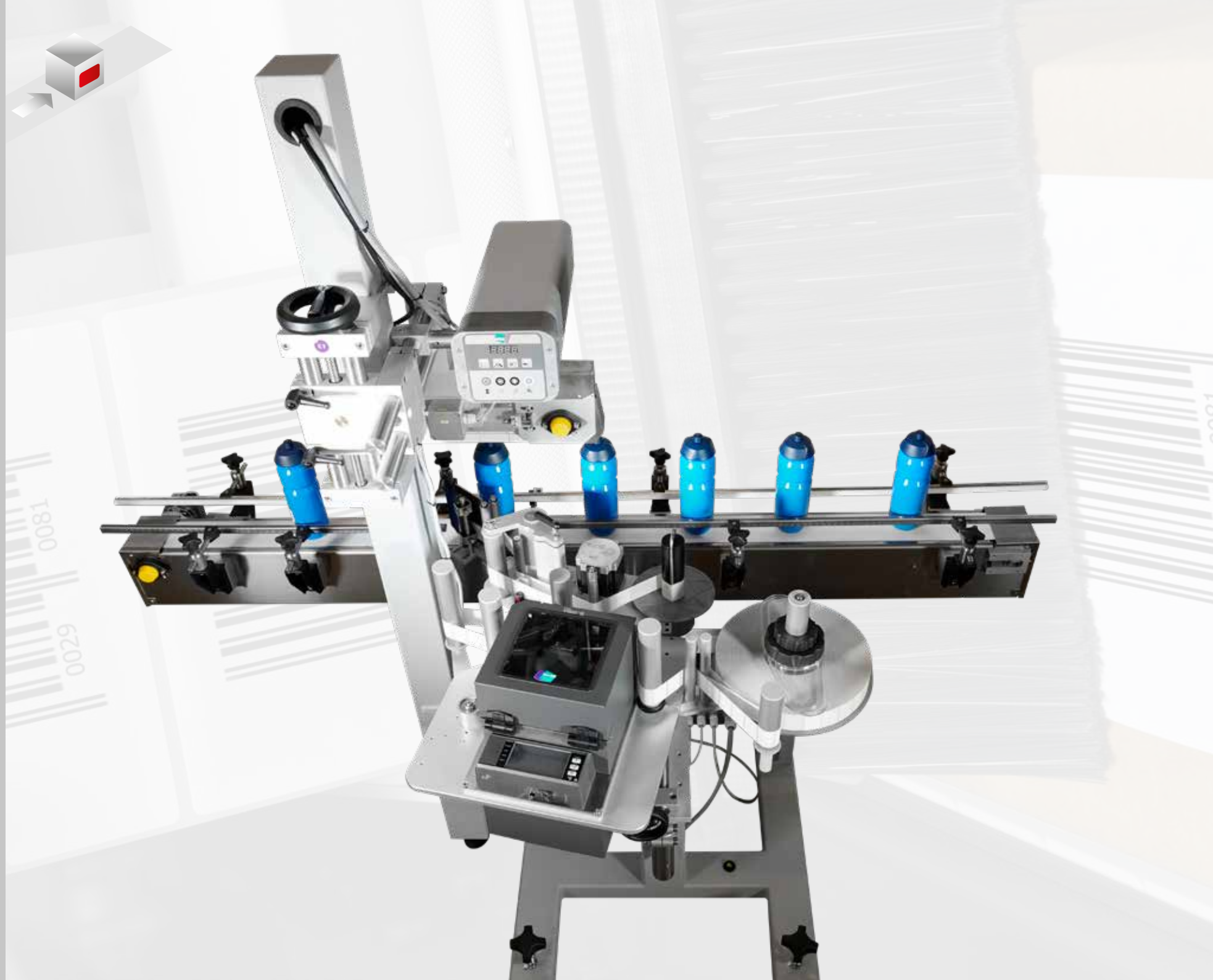

Light



*Iron finish
(special black color on demand)
2 labelers in Non Stop
configuration with "fine placement"*

*Finitura Iron
(colore speciale nero a richiesta)
2 Etichettatrici in configurazione
Non Stop con "fine placement"*



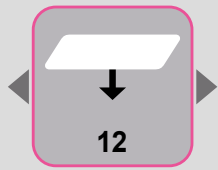

TOP

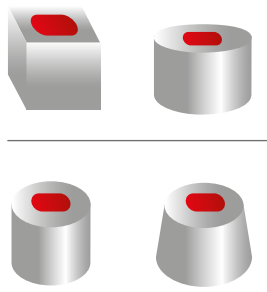

System with thermal inkjet printing module (HP compatible). Ideal for labeling on Blow Fill Seal (BFS) bags

Sistema con modulo di stampa inkjet termico (compatibile HP). Ideale per etichettatura su sacche BFS (Blow Fill Seal)

Light

*Ideal for single-dose strip labeling,
thanks to the “multi-application”
function of Arca labelers*



Ideale per etichettatura di strip
monodose, grazie alla funzione “multi-
applicazione” delle etichettatrici Arca

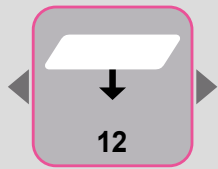

TOP

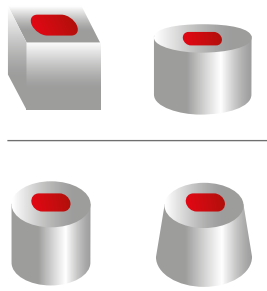

Side stabilizer for limited eight products, even fragile

Stabilizzatore laterale per prodotti di altezza limitata, anche fragili



Light

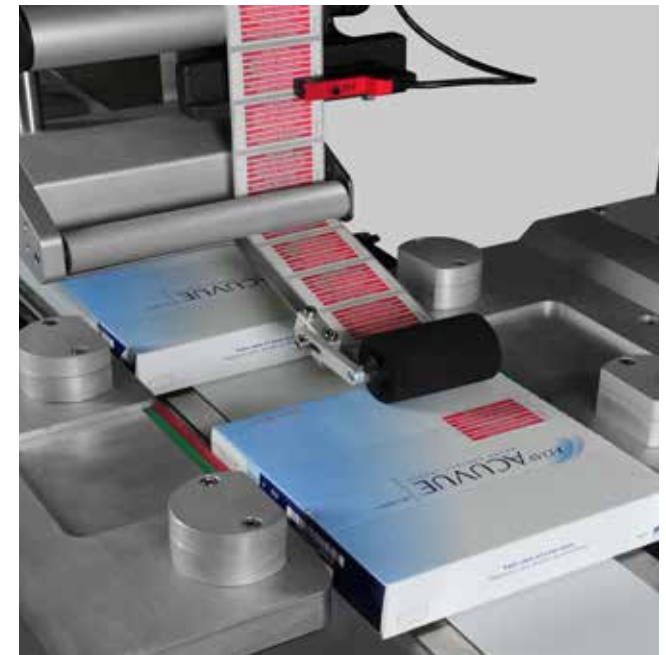



Motorized adapter can be used for adapting on critical surfaces

Adattatore motorizzato utilizzabile per l'adattamento su superfici critiche

Top labeling on product with convex profile, via articulated peeler

Etichettatura Top su prodotto di sagoma convessa, mediante staccatore articolato



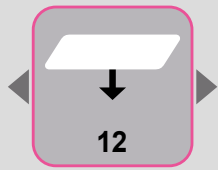

TOP

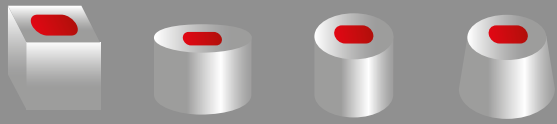

Iron finish: scratch-resistant epoxy powder-coated steel. Adjustable table height, cable routing inside the tubulars

Finitura Iron: acciaio trattato a polvere epossidica antigraffio. Altezza del piano regolabile, passaggio cavi all'interno dei tubolari

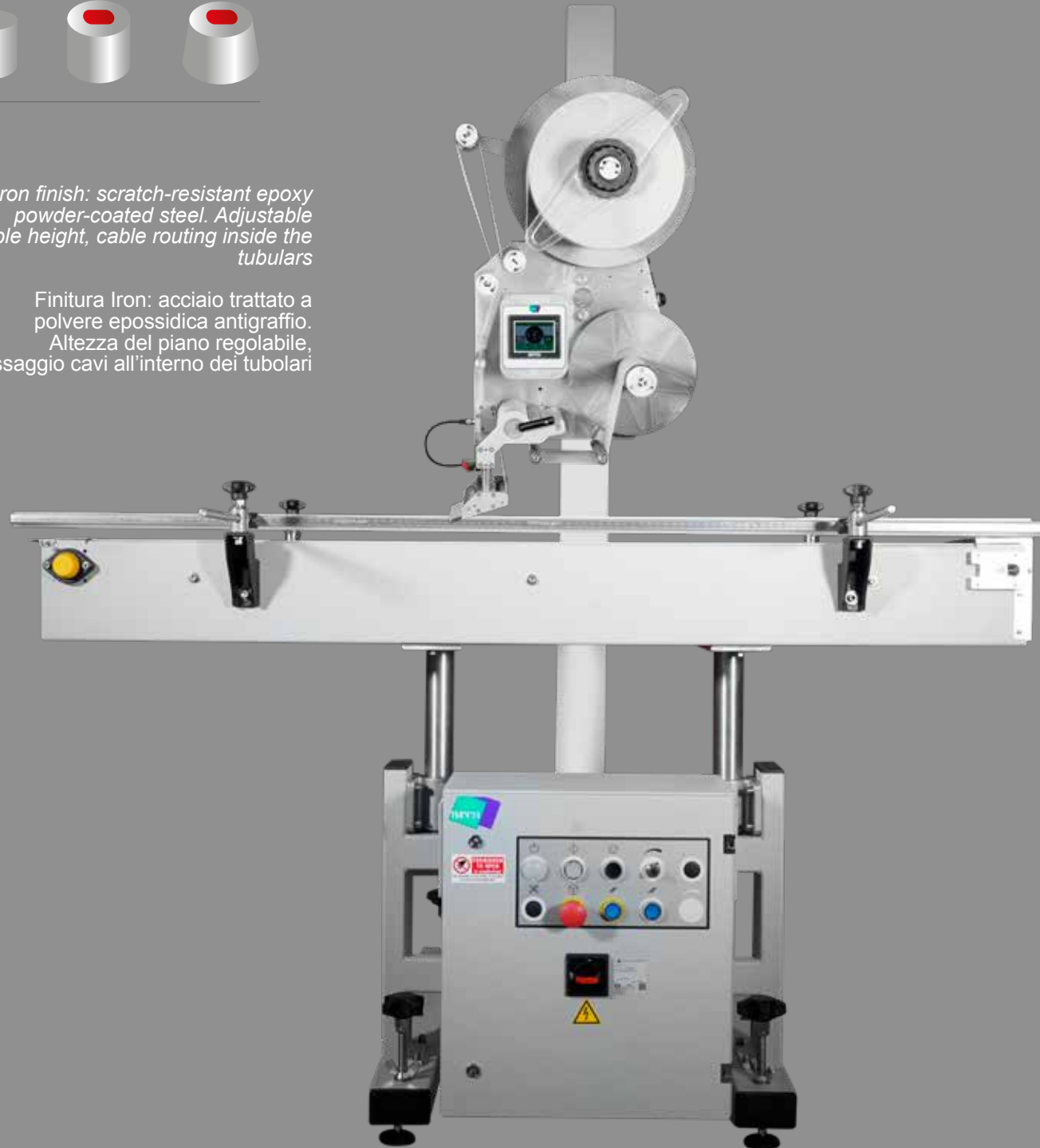

Light

*Can also be used for the
installation of any type of marker
or line device*

Utilizzabile anche per
l'installazione di qualsiasi tipo di
marcatore o dispositivo di linea



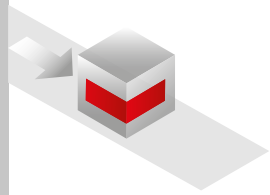

FRONT SIDE



Light

Labeler with thermal transfer printing and Concorde articulated peeler

Etichettatrice con stampa a trasferimento termico e staccatore articolato Concorde





15.24

FRONT TOP BASE

c-wrapping

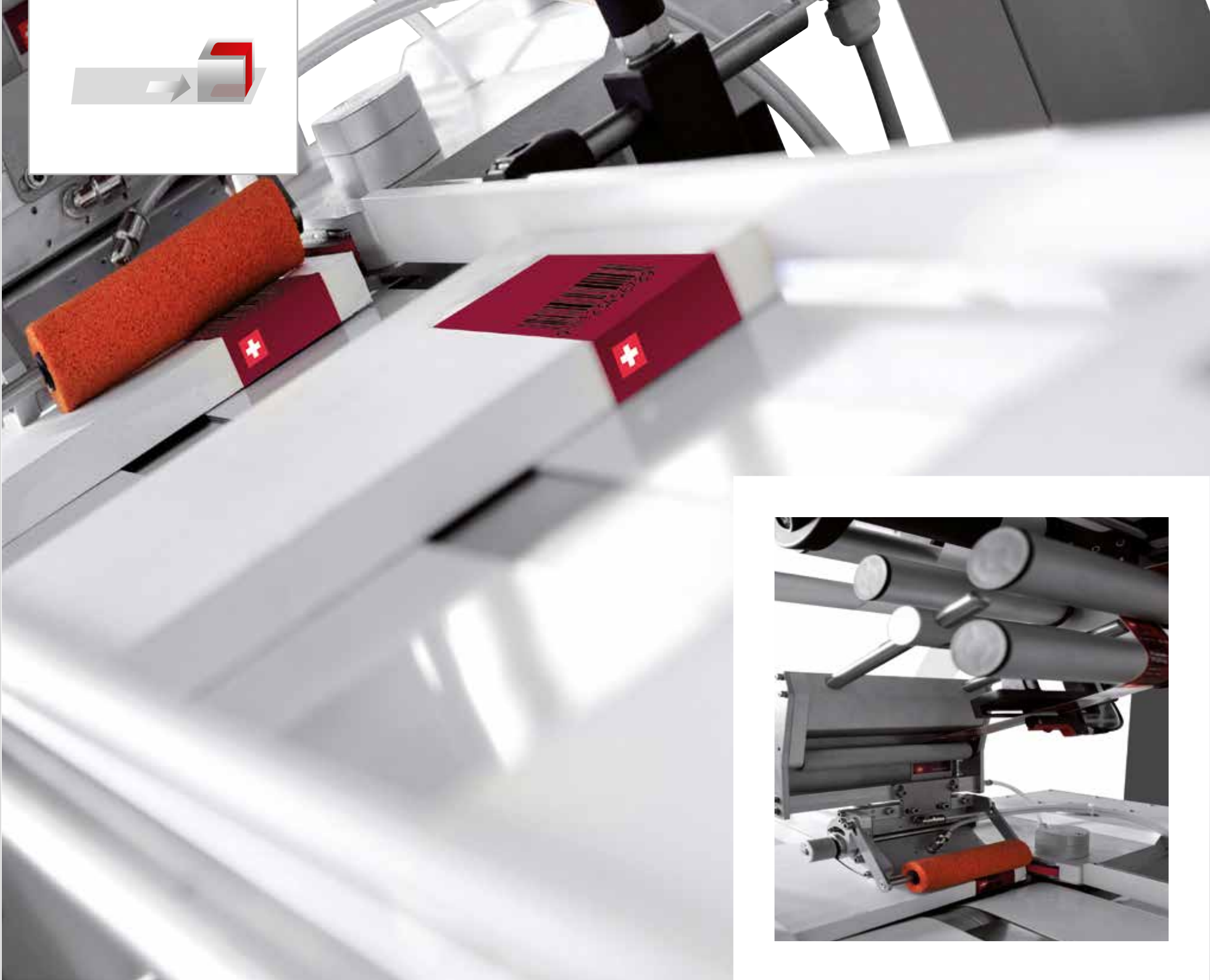

Light

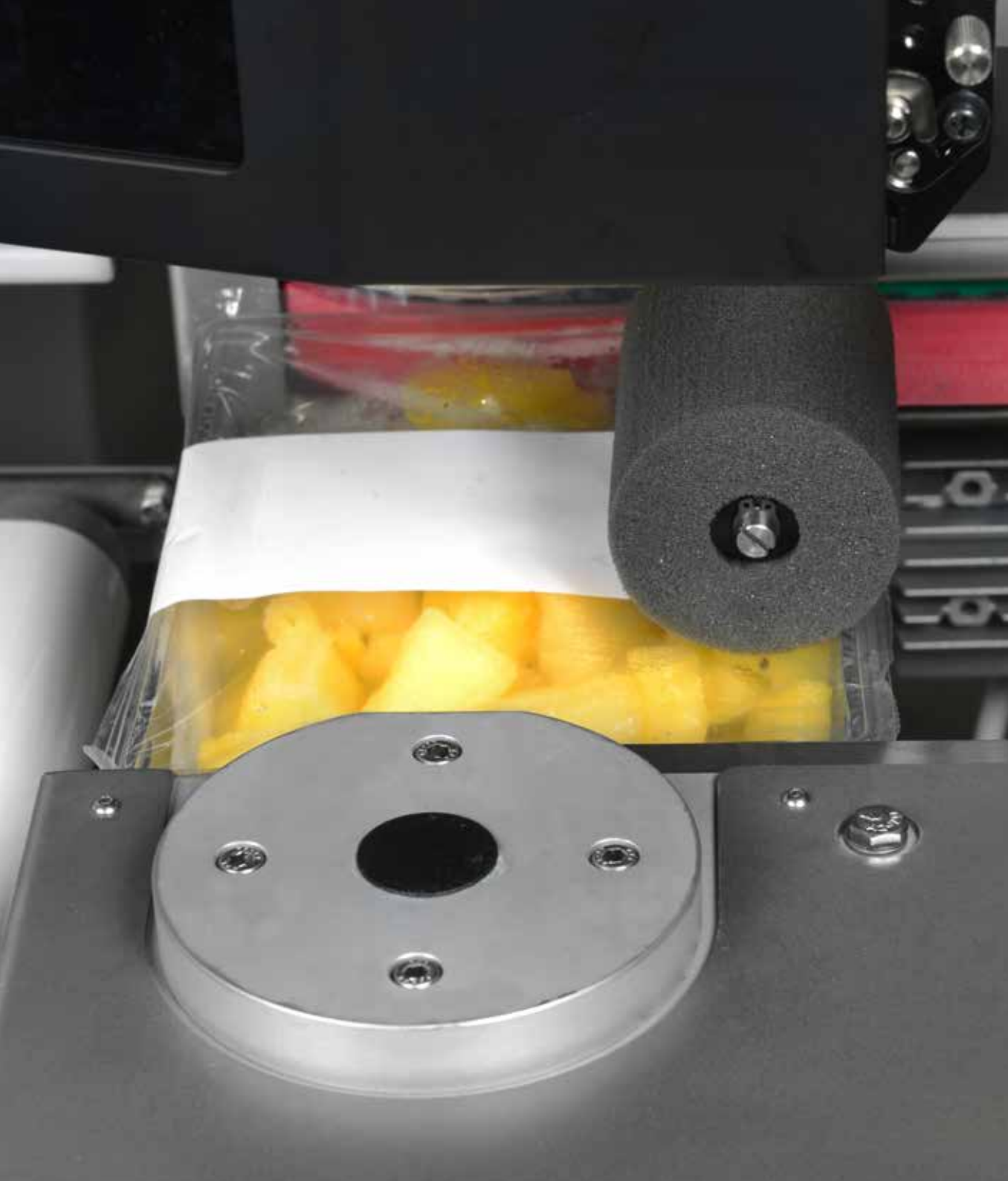

c-wrapping

27



Front Top Base

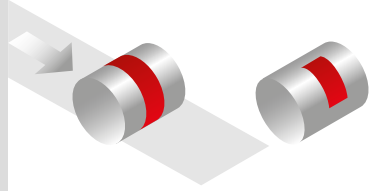

WRAP AROUND DOWN



Light





WRAP AROUND DOWN

Light

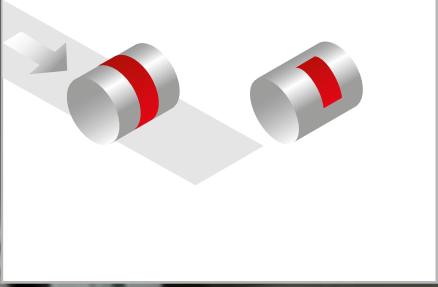

Cylindrical, unstable products fed in a horizontal position on an idler roller conveyor. Includes an upper wrapping unit for wraparound labeling

Prodotti cilindrici, instabili, trasportati in posizione orizzontale mediante convogliatore a rulli folli. Con rotolatore superiore per l'etichettatura avvolgente

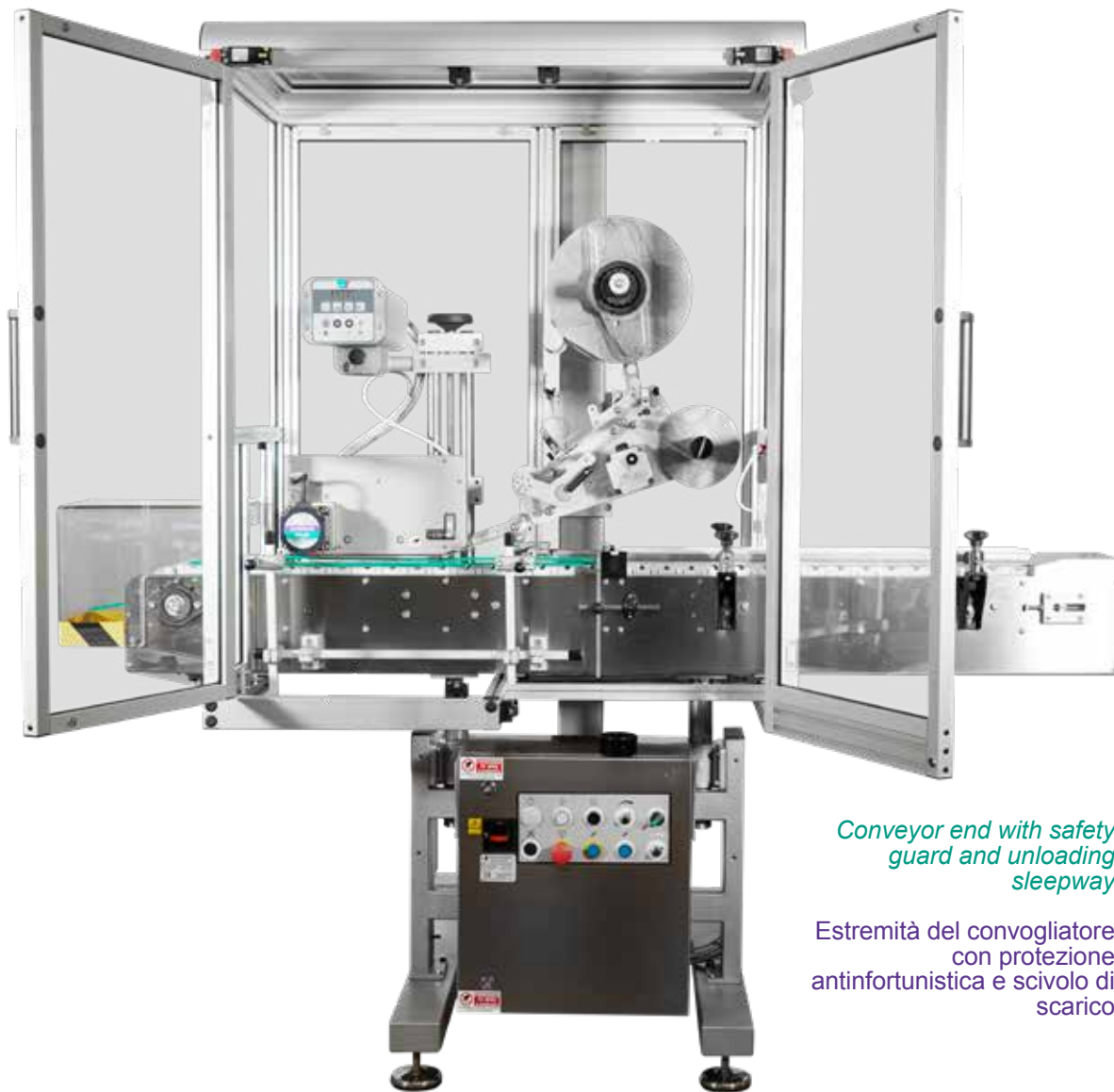

Conveyor end with safety guard and unloading sleepway

Estremità del convogliatore con protezione antinfortunistica e scivolo di scarico

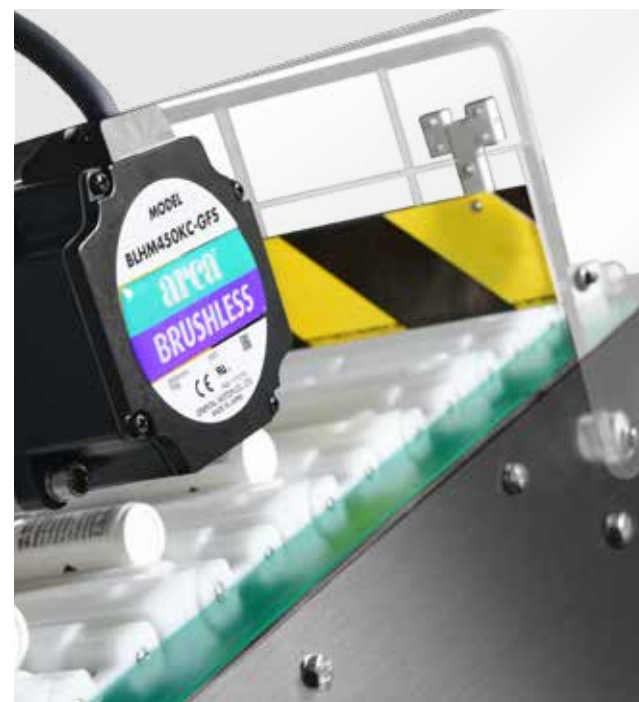



WRAP AROUND DOWN *indexed*

Light

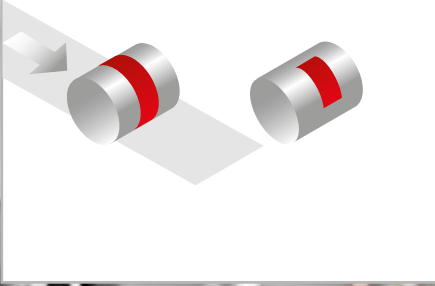



Indexed positioning device for “flat-lying” (horizontal) products, with an alternate motion product feed system. When paused the product is rotated and positioned so as to detect a mark stamped on the packaging

Posizionatore a registro per prodotti “abbattuti” (orizzontali) con avanzamento a moto alternato. Il prodotto, durante l’arresto, viene posto in rotazione e posizionato rilevando una tacca stampata sulla confezione

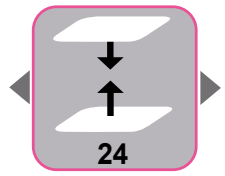

TOP&BASE

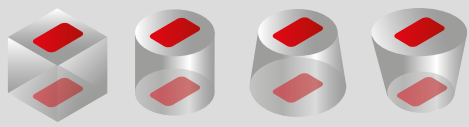



Highly robust and expandable systems, with the possibility of placing the labelers on both operating sides. The Solid series offers all the advantages of the Light systems as well as:

- in the Side configurations, labelers positioned on the operator side, to simplify the periodic depleted label roll change
- color display or graphical interface on industrial PC
- Combi configuration
- Skytech model (in Low Level version too) and Hightech
- very high productivity Non Stop configuration

I lati di applicazione sono quelli del prodotto, sui quali si etichetta o si marca direttamente. I lati di applicazione o marcatura sono identificati da numeri convenzionali. I primi due numeri indicano, univocamente, il lato o i lati sui quali l'etichetta viene "applicata".

I numeri oltre il punto indicano i lati sui quali l'etichetta viene eventualmente adattata:

- .1 adattamento sul lato Side
- .2 adattamento sul lato Top
- .4 adattamento sul lato Base
- .5 adattamento sul lato Front
- .6 adattamento sul lato Back
- .11 adattamento sui lati Two Sides
- .114 adattamento sui lati Two Sides e Base
- .116 adattamento sui lati Two Sides e Back
- .1144 adattamento sui lati Two Sides e Two Base
- .14 adattamento sui lati Side e Base
- .22 adattamento di due etichette sul lato Top
- .24 adattamento di una o due etichette sul lato Top e sul lato Base
- .44 adattamento di due etichette sul lato Base
- .56 adattamento sui lati Front e sul lato Back

Solid Series

Labeling Systems

Sistemi robustissimi ed espandibili, con possibilità di collocare le etichettatrici su entrambi i lati operativi. La serie Solid offre tutti i vantaggi dei sistemi Light ed inoltre:

- nelle configurazioni Side, etichettatrici posizionate sul lato operatore per facilitare la sostituzione periodica del rotolo di etichette esaurito
- display a colori o interfaccia grafica su PC industriale
- configurazione Combi
- modelli Skytech (anche in versione Low Level) e Hightech
- configurazione Non Stop ad altissima produttività



4
labels

3
labels

2
labels

1
label

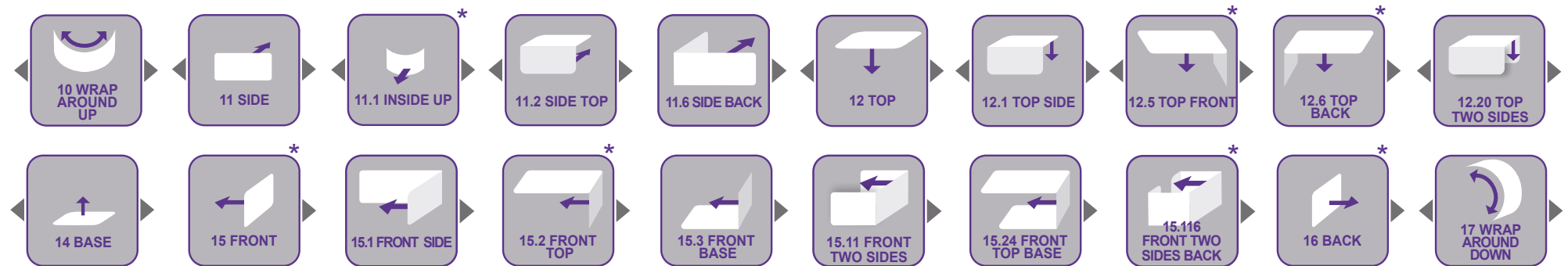
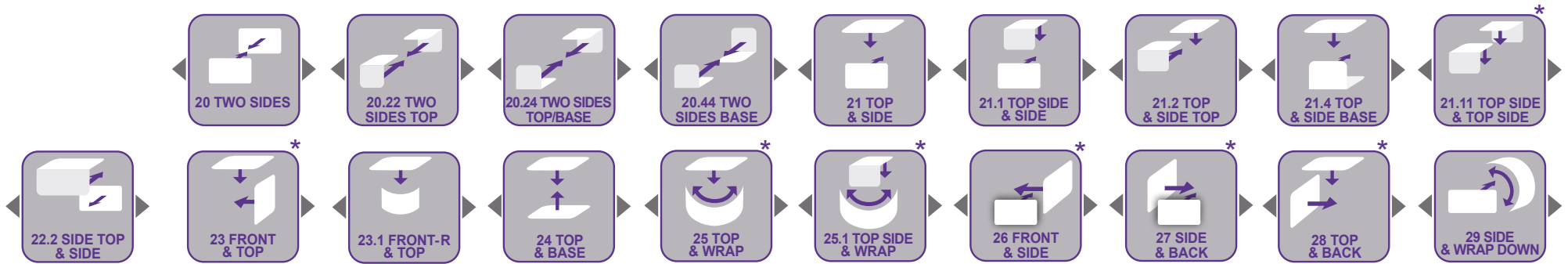

Operator interface on a 4.3 "colour touch screen display. Includes the following fundamental features:

- 200 "product programs" each identifiable with a name of up to 15 alphanumeric characters
- "safe start-up" of the system; that is start-up preceded by a warning of the eventual acoustic / luminous signaling device with programmable delay
- flashing green light to indicate "stand by" status
- controlled shutdown to avoid the interruption of the labeling in progress and conclude the processing of all the products already inside the machine
- length control (pitch) of the products, aimed at intercepting any products of different sizes (wrongly loaded on the line) or "knocked down" (overturned) or not adequately spaced apart
- management of the controls for automatic ejection, without line stoppage, of "non-labeled" products or of products with improperly over-printed labels. Physical movement of the sensor photocells is not required, nor is the ejector (neither at format change nor in case of speed variation)

Digital MMI

Interfaccia operatore su display touch screen a colori 4,3". Include le seguenti funzioni fondamentali:

- 200 "programmi prodotto" identificabili ciascuno con un nome di max 15 caratteri alfanumerici
- "avviamento in sicurezza" del sistema; ovvero avviamento preceduto da un preavviso dell'eventuale segnalatore acustico/luminoso con ritardo programmabile
- accensione lampeggiante della luce verde per indicare lo stato "di stand by"
- arresto controllato per evitare l'interruzione dell'etichettatura in corso e concludere la lavorazione di tutti i prodotti già all'interno della macchina
- controllo lunghezza (passo) dei prodotti, finalizzato a intercettare eventuali prodotti di diverso formato (erroneamente caricati sulla linea) o "abbattuti" (ribaltati) o non adeguatamente tra loro distanziati
- gestione dei controlli per espulsione automatica, senza arresto linea, dei prodotti "non etichettati" o dei prodotti con etichette non correttamente sovra-stampate (verifica di 1 etichetta). Non è richiesto lo spostamento fisico delle fotocellule dei sensori, né dell'espulsore (né al cambio formato, né in caso di variazione della velocità)



Operator interface by 10 "industrial colour PC panel, MS Windows Embedded and solid state drive (SSD). Simple and intuitive graphics with representation of the machine layout and alarm location. Includes all the fundamental functions and furthermore:

- centralized management of printing devices, code readers and vision systems
- production data collection
- traceability of labelled products (for batch and order)
- Ethernet port on HUB/Switch and USB port accessible from the outside, for exporting data in SQL format
- biometric access control
- user profiling with different degrees of authority (compatible Windows Active directory)
- CFR21, part. 11 compliant. Access timings, encrypted "audit trail" with registration of all the operations performed

Graphic MMI 4.0

Interfaccia operatore su panel PC industriale 10" a colori, MS Windows Embedded, disco a stato solido (SSD). Grafica semplice e intuitiva con rappresentazione del layout macchina e localizzazione allarmi. Include tutte le funzioni fondamentali e inoltre:

- gestione centralizzata dei dispositivi di stampa, dei lettori di codici e dei sistemi di visione
- rilevazione dati di produzione
- tracciabilità univoca dei prodotti etichettati (per lotto e ordine)
- porta Ethernet su HUB/Switch e porta USB accessibile dall'esterno, per esportazione dati in formato SQL
- controllo biometrico degli accessi
- profilazione utenti con diversi gradi di autorità (compatibile Windows Active directory)
- Conforme CFR21 part. 11. Temporizzazioni accessi, "audit trail" criptato, con registrazione di tutte le operazioni effettuate



Solid Skytech: the model with the “uplifted” electrical system cabinet, near the power supply. To wash and clean more freely. Even in the Low Level version with the worktop particularly low, to allow the easier operation on lines that deal heavy products

“Sliding door” shielding (upward opening). Available for all the Solid systems (Side labeling). For the least obstruction and to avoid any obstruction to the MMI when doors are opened. It protects the system from dust and reduces noise pollution. The reel housing is accessible even with the covers down

Skytech & Sliding door protection

Solid Skytech: il modello con l'armadio dell'impianto elettrico “sopraelevato”, in prossimità dell'alimentazione. Per lavare e pulire più liberamente. Anche nella versione Low Level con il piano di lavoro particolarmente basso, per consentire la più agevole operatività su linee che trattano prodotti pesanti

Cabinatura “sliding door” (apertura verticale). Disponibile per tutti i sistemi Solid (applicazioni Side). Per il minimo ingombro e per non intralciare l'accesso all'MMI anche a protezioni aperte. Preserva il sistema dalla polvere e riduce l'inquinamento acustico. L'alloggiamento rotolo è accessibile anche a protezioni chiuse



Skytech Low Level

*Special guides, in stainless steel,
for "handle lifting"*

Guide speciali, in acciaio inox,
per il "sollevamento manici"



Non Stop coordinates two labelers placed in line, ensuring functional continuity. Each labeler starts automatically when the other one stops due to:

- *depleted label reel. Non Stop guarantees the labeling of products that are between the two applicators, even when switching from the downstream labeler to the upstream one*
- *breakdown or machine in alarm for whatever reason (e.g. silicon liner tearing)*

Non Stop

Non Stop coordina due etichettatrici collocate in batteria, garantendo la continuità di funzionamento.

Ogni etichettatrice parte automaticamente quando l'altra si arresta per:

- esaurimento rotolo etichette. Non Stop garantisce l'etichettatura dei prodotti che si trovano tra i due applicatori, anche nel passaggio dall'etichettatrice a valle, a quella a monte
- guasto o macchina in allarme per qualsiasi ragione (es: rottura del supporto siliconato)

Skytech system for labeling 11 Side in Non-Stop configuration

Sistema Skytech per etichettatura 11 Side in configurazione Non Stop



The pneumatic slide allows for the extraction of the labeler on alarm; essential for the easy replacement of the depleted label reel. Thanks to the slide, after reinstatement, the machine is put back into the perfect position for the best functioning

La slitta pneumatica consente l'estrazione dell'etichettatrice in allarme; indispensabile per l'agevole sostituzione del rotolo etichette esaurito. Grazie alla slitta, dopo il ripristino la macchina viene riportata nella posizione perfetta per il miglior funzionamento



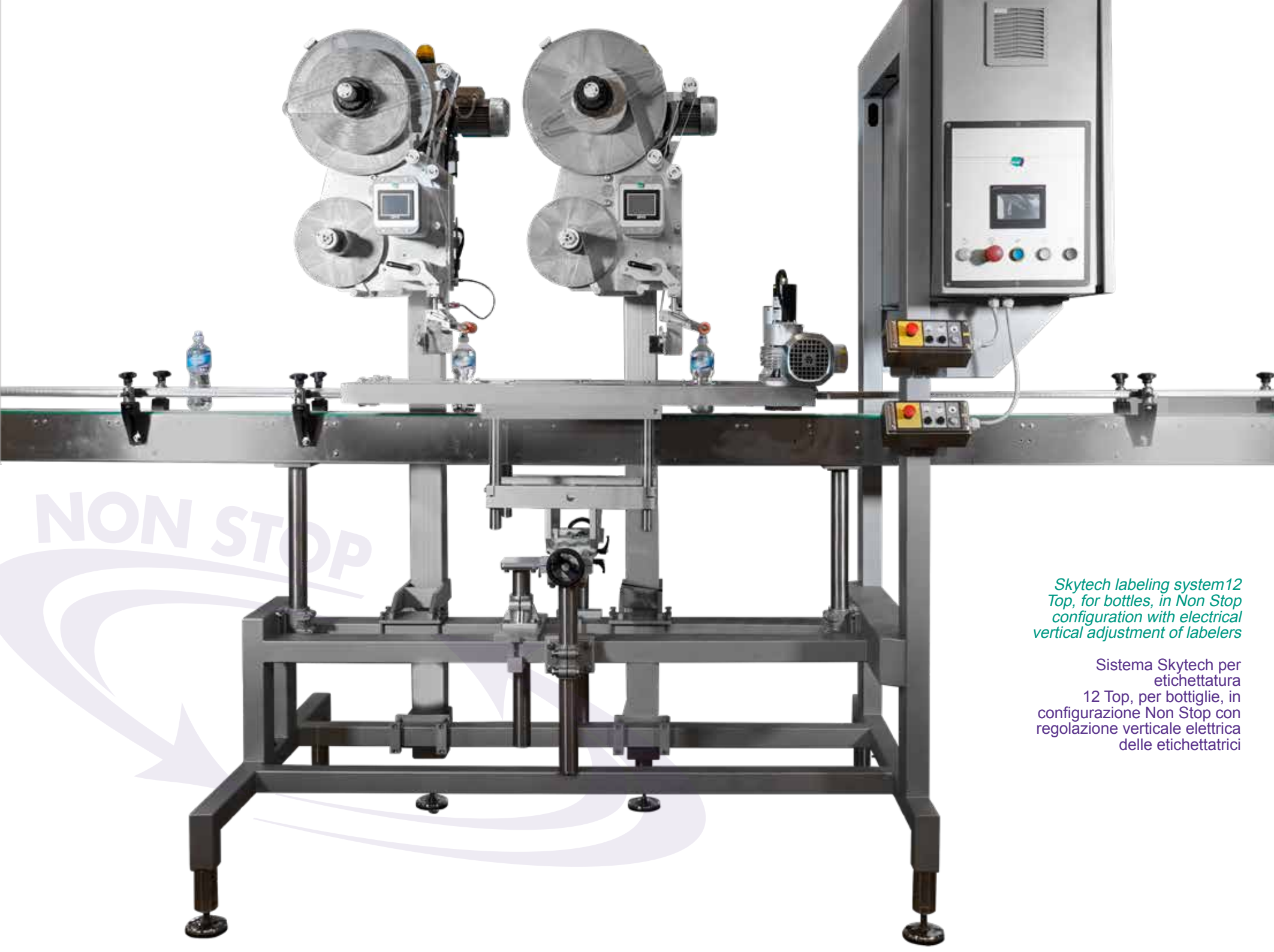

Skytech labeling system 12 Top, for bottles, in Non Stop configuration with electrical vertical adjustment of labelers

Sistema Skytech per etichettatura 12 Top, per bottiglie, in configurazione Non Stop con regolazione verticale elettrica delle etichettatrici



WRAP AROUND UP

Solid



*Labeler with thermal transfer printing module.
Protection that can be opened on both sides to "gull-wing"*

*Etichettatrice con modulo di stampa a trasferimento termico.
Protezione apribile su entrambi i lati ad "ala di gabbiano"*







WRAP AROUND UP

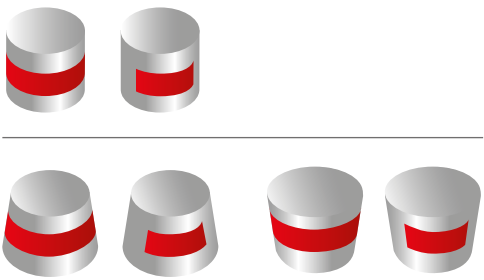

*Single-sided compact system
("balcony" style) length 1600mm.
The "open frame" structure facilitates
cleaning operations*

Sistema compatto monolaterale
("a balcone") lunghezza 1600mm.
La struttura "open frame" facilita le
operazioni di pulizia

*All adjustments (including those of
the product guides) are operable
from the operator side*

Tutte le regolazioni (anche quelle
delle guide prodotti) sono operabili
dal lato operatore

**Solid
compact**



Labeler with the possibility of printing variable data with one of the following technologies:

- thermal transfer marker
- thermal inkjet
- laser marker which does not require consumables and guarantees maximum reliability

Etichettatrice con possibilità di stampa dei dati variabili con una delle seguenti tecnologie:

- marcatore a trasferimento termico
- inkjet termico
- marcatore laser che non richiede consumabili e garantisce la massima affidabilità



"Product height" control for verifying correct closure of the product

Controllo "altezza prodotto" per la verifica di corretta chiusura del prodotto





WRAP AROUND UP

Solid



Rotating accumulation table for labeled products

Tavola rotante di accumulo per prodotti etichettati

1

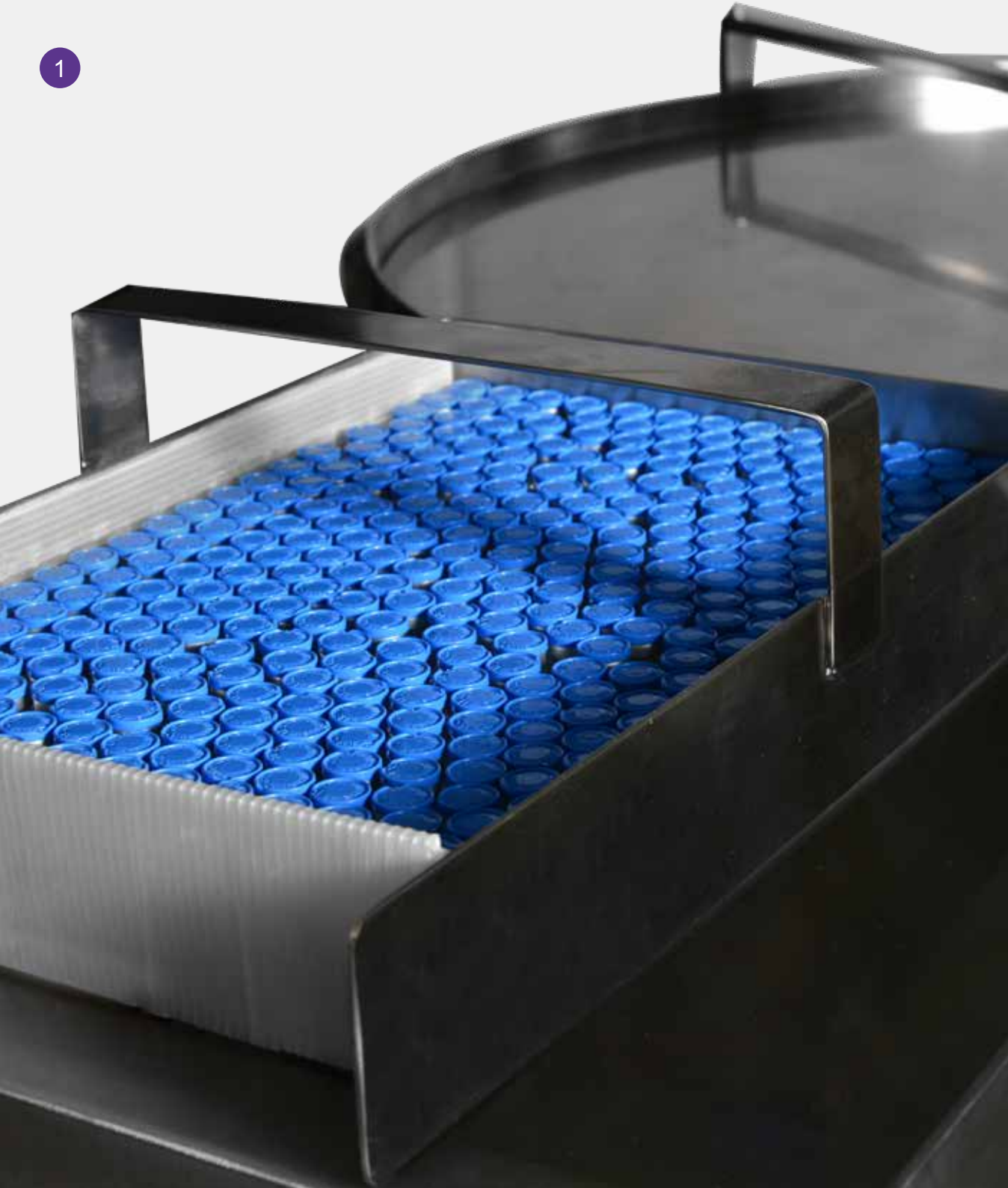

The labeling system is normally inserted in the automatic production line. Alternatively, it can be loaded by a manually loaded rotating table; the discharge can be on the production line or on a second rotating table or on a linear "controlled" storage section (intelligent start and stop), always for manual unloading

Il sistema di etichettatura è normalmente inserito nella linea di produzione automatica. In alternativa, può essere alimentato da una tavola rotante a caricamento manuale; lo scarico può essere sulla linea produttiva o su una seconda tavola rotante o su un tratto di accumulo lineare "controllato" (start e stop intelligente), sempre per scarico manuale

49

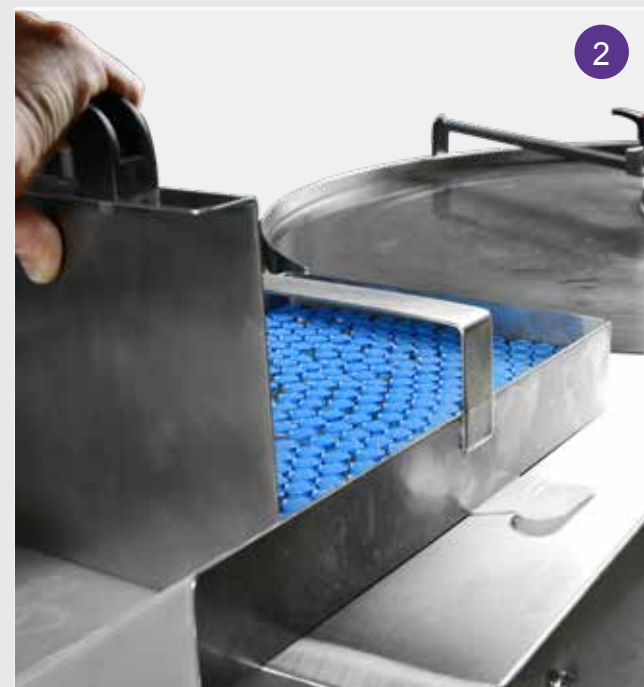



WRAP AROUND UP *indexed*

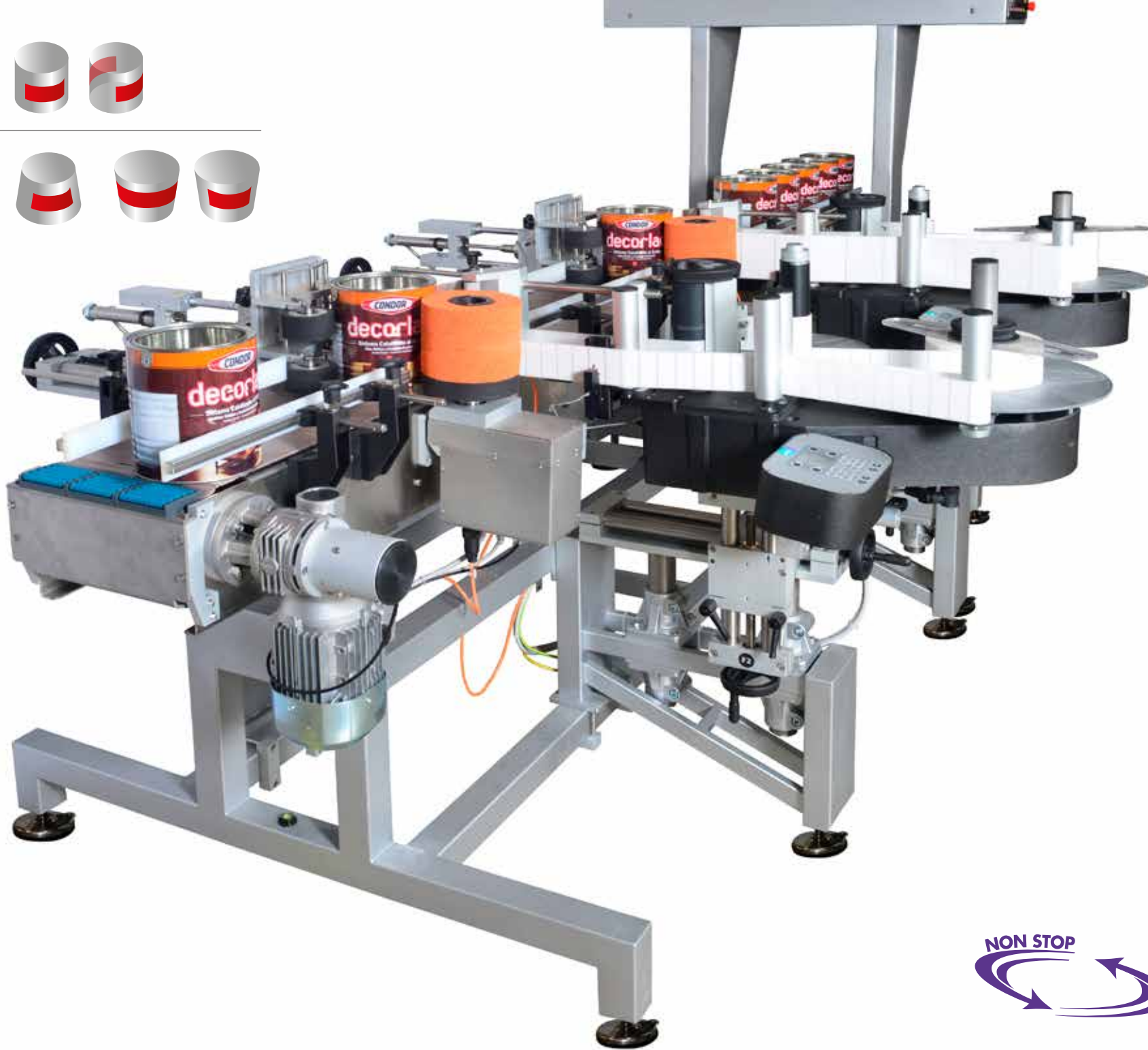
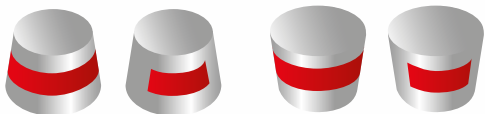

Solid





CONDOR

decorla

ma Catalizado
Sólidos y Excelente
Secado





WRAP AROUND UP *indexed*

Solid



Thanks to an “indexed” labeling positioner the product is rotated, to allow for the application at a specific point on cylindrical (or single format conical) products of various dimensions. The labeling point is established with respect to a colored reference mark (full color background or soldering of the sealing strip) positioned on the circumference of the product. The positioner can also carry out the rotating function only, allowing for the carrying out of the wrap around labeling with random positioning (mark reading deactivated or not installed)

Grazie ad un posizionale “a registro” il prodotto viene ruotato, per consentire l'applicazione in un punto specifico di prodotti cilindrici (o conici monoformato) di varie dimensioni. Il punto di etichettatura è stabilito rispetto ad una tacca cromatica di riferimento (fondo di colore pieno o saldatura della banda stagnata) posizionata sulla circonferenza del prodotto. Il posizionale può svolgere anche la sola funzione di rotolatore, consentendo di effettuare l'etichettatura avvolgente con posizionamento casuale (lettura tacca disabilitata o non installata)





WRAP AROUND UP *conical*

Solid

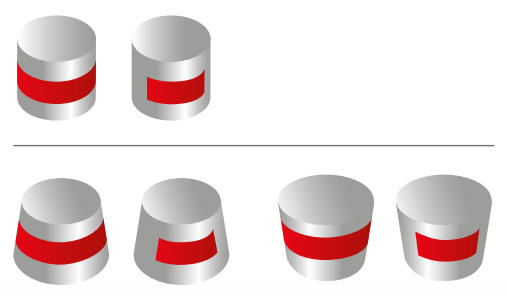





SIDE

Solid

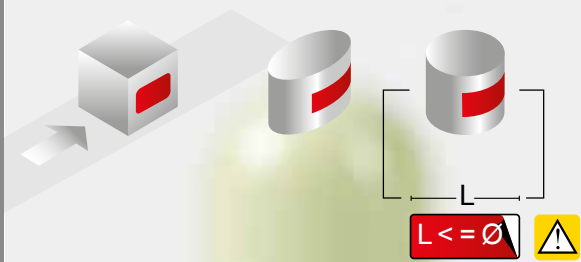



11.2

SIDE TOP

Solid

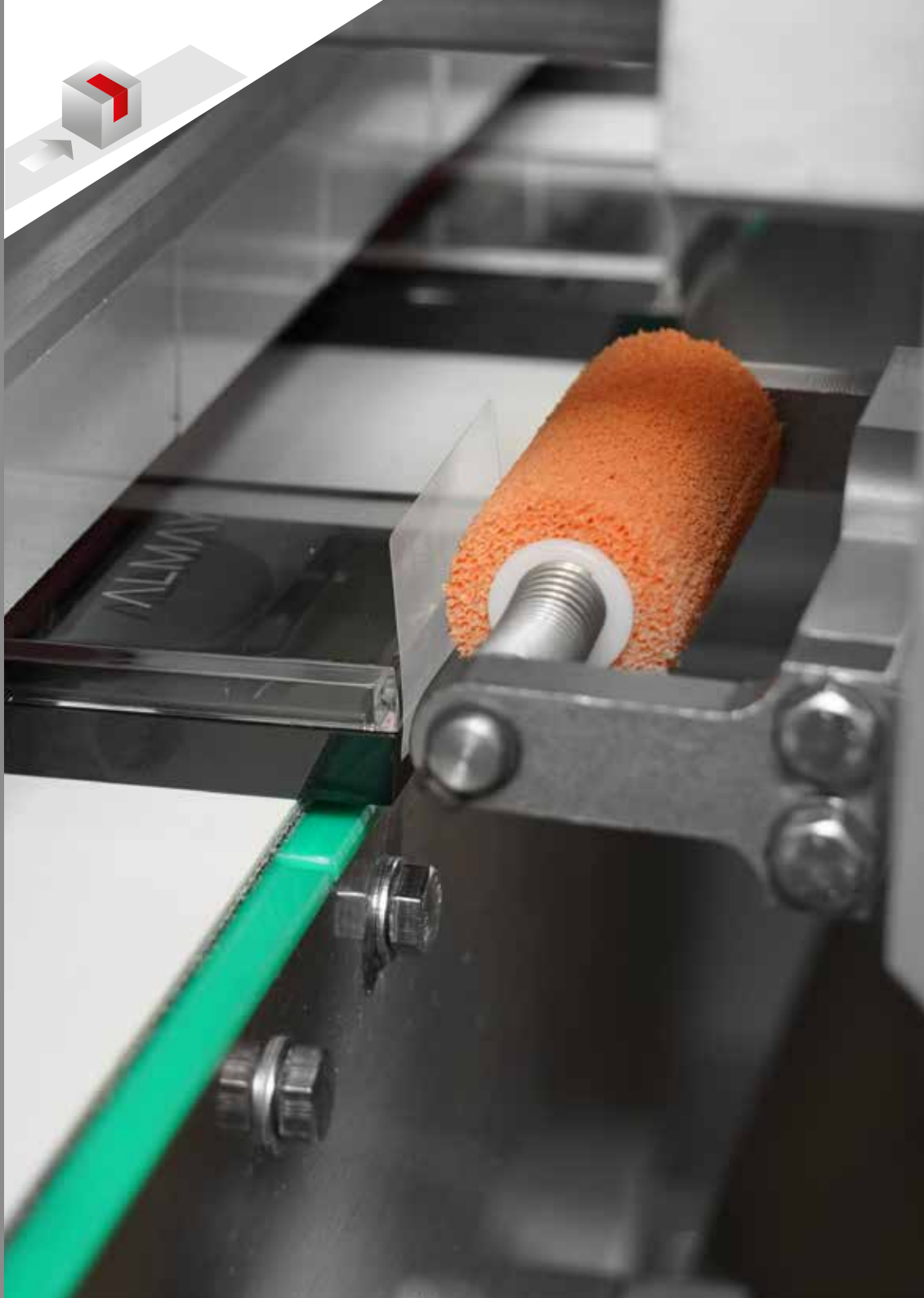

Spacer and Seal-L Side roller adapter with local safety guard (with safety microswitch embedded) and adjustment accessible from outside

Distanziatore e adattatore a rullo Seal-L Side con protezione localizzata (cerniere con micro interruttore di sicurezza incorporato) e regolazione accessibile dall'esterno



57

Side - Side Top



11.6

SIDE BACK

Solid

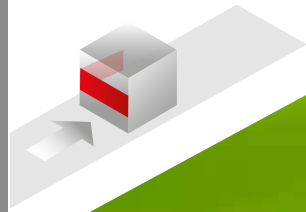

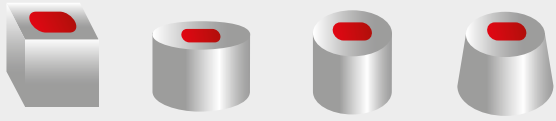
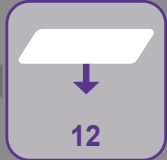

TOP





TOP SIDE seal

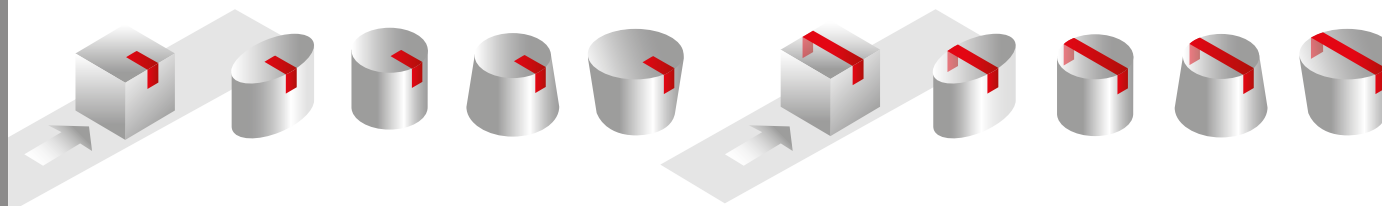

*Upper stabilizer with one or two adapters, respectively for "L" or "U" seals
The pneumatic Seal adapter shifts horizontally, following the passage of the product*

Stabilizzatore superiore con uno o due adattatori, rispettivamente per sigilli a "L" o a "U" L'adattatore pneumatico Seal trasla orizzontalmente, seguendo l'avanzamento del prodotto



33
Mgna di
11 BIO 007
PRODOTTO BIOLOGICO
Preparazione di mirtili rossi
senza zuccheri aggiunti
Ingredienti: mirtili rossi, zucchero,
acido citrico, pectina, aromi naturali.
Conservare in frigorifero a 4°C.
Data di scadenza: 12/2024
Cottimo
Cottimo

SIGILLO DI GARANZIA
SEAL
SECURITEITSIEGEL
SICHERHEITSGARANTIE
CACHET DE GARANTIE

CapSULA DI SICUREZZA
MIRTYL ROSSI
MIRTYL ROSSI
MIRTYL ROSSI
MIRTYL ROSSI



14

BASE

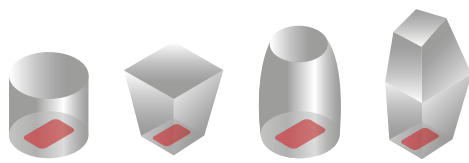

System with Vario conveyor for unstable products

Sistema con convogliatore Vario per prodotti instabili

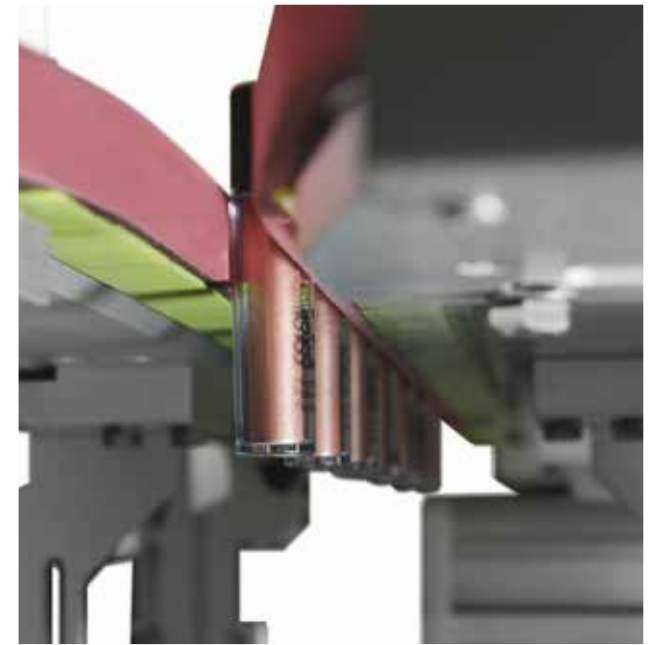

Vario conveyor for Top and/or Base labeling of unstable products. Two lateral belts withdraw the product from the upstream line (as long as it's correctly positioned) and deposit it, after labeling, on the downstream line. The version with rubber belts allows for conducting the products (with regular profile) in precise position. An air blast micro applicator allows for labeling even in hollow bases

Convogliatore Vario per l'etichettatura Top e/o Base, di prodotti instabili. Due nastri laterali prelevano il prodotto dalla linea a monte (purché correttamente posizionato) e lo depositano, dopo l'etichettatura, sulla linea a valle. La versione a cinghie in gomma, consente di veicolare i prodotti (con sagoma regolare) in posizione precisa. Un microapplicatore a soffio d'aria consente l'etichettatura anche in sedi incavate

Solid

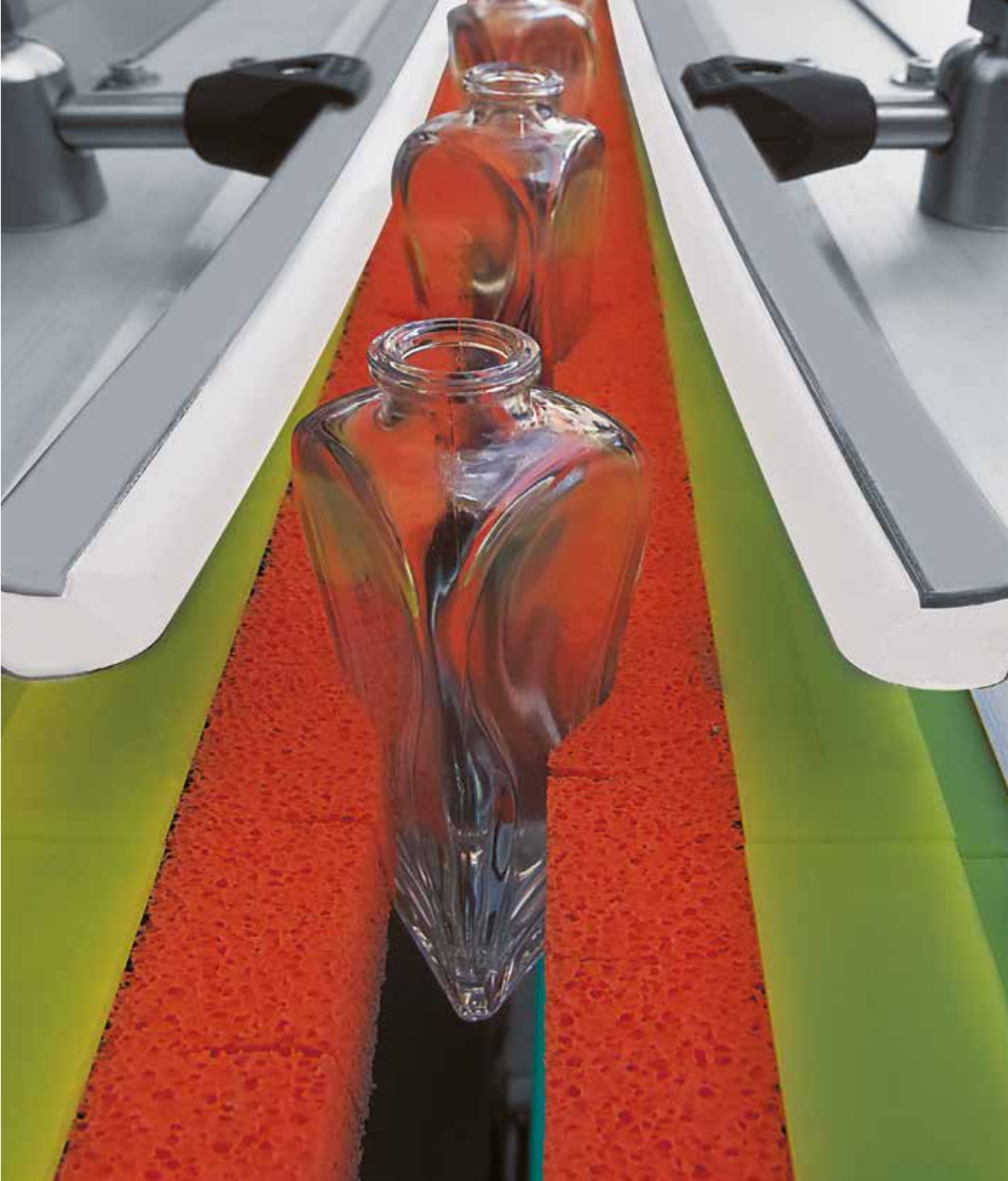

Light products with irregular profiles can be conducted in vertical position via the Vario conveyor for unstable products, in the version with independent segments of flexible sponge

I prodotti leggeri di sagoma irregolare possono essere veicolati in posizione verticale mediante il convogliatore Vario per prodotti instabili, nella versione a segmenti indipendenti di spugna conformabile





15.1

FRONT SIDE

Solid



The articulated Concorde peeler applies the label on the front of the product in movement and adapts it making it stick onto the adjacent side too

Lo staccatore articolato Concorde applica l'etichetta sul fronte del prodotto in movimento e l'adatta facendola aderire anche sul lato adiacente





15.11

FRONT TWO SIDES c-wrapping

Solid

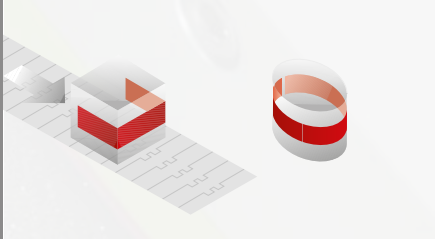

Labeler with additional
C-Wrapping adapter

Etichettatrice con
adattatore aggiuntivo
C-Wrapping

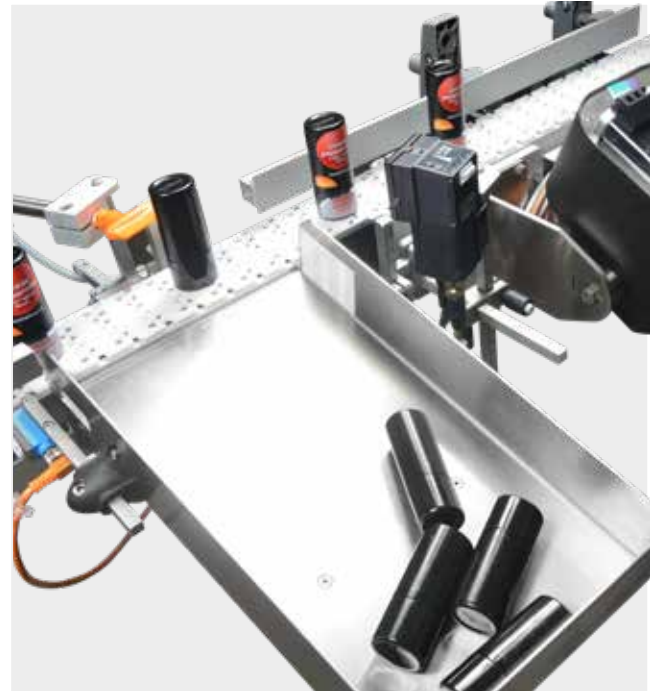

65

Front Side - Two Sides



WRAP AROUND DOWN

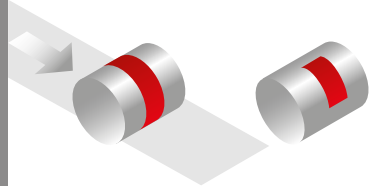

Pharmaceutical labeling system for cylindrical and unstable products, transported in a horizontal position via a feed conveyor with idle rollers. Graphic interface and operation in positive logic; continuous motion feed for high productivity; automatic removal and repositioning of labelers and wrapping units on roll changes; check for one barcode placed randomly on the product's circumference (with ejector), and lot traceability, based on unique codes; programmable lots packing using 2 or 4 alternate unloading station and package label generation; compartmentalized protection, for maximum security during "reel changing" operations

Sistema farmaceutico per l'etichettatura di prodotti cilindrici, instabili, trasportati in posizione orizzontale mediante convogliatore a rulli folli. Interfaccia grafica e funzionamento in logica positiva; avanzamento a moto continuo per alta produttività; allontanamento e riposizionamento automatico delle etichettatrici e dei rotolatori, al cambio rotolo; controllo di un barcode posizionato casualmente sulla circonferenza del prodotto (con espulsore) e tracciabilità del lotto, in base ai codici univoci; confezionamento a lotti programmabili con 2 o 4 stazioni di scarico alternato e generazione dell'etichetta imballo; protezione compartimentata per la massima sicurezza anche durante le operazioni di "cambio rotolo"



**Solid
Skytech**

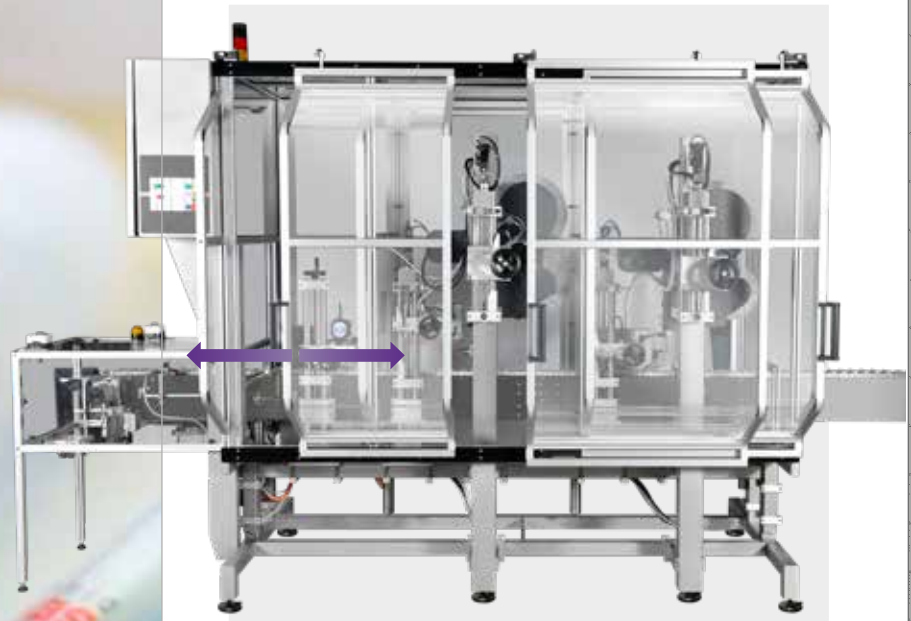

Reverse side with sliding doors for limited encumbrance
Retro con apertura scorrevole a ingombro limitato



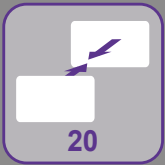

TWO SIDES

Solid

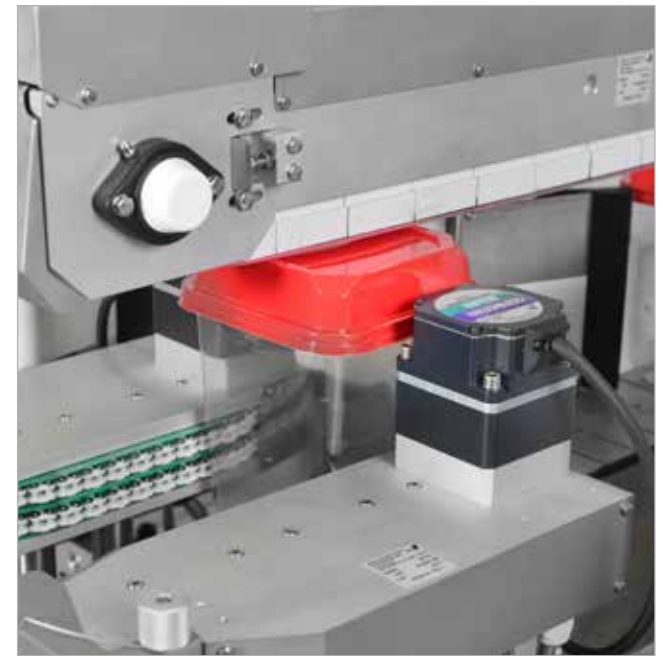





TWO SIDES

Solid

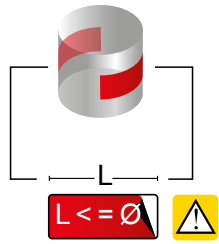
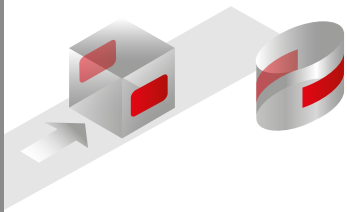



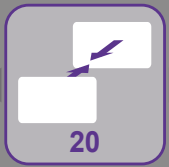

TWO SIDES

Solid

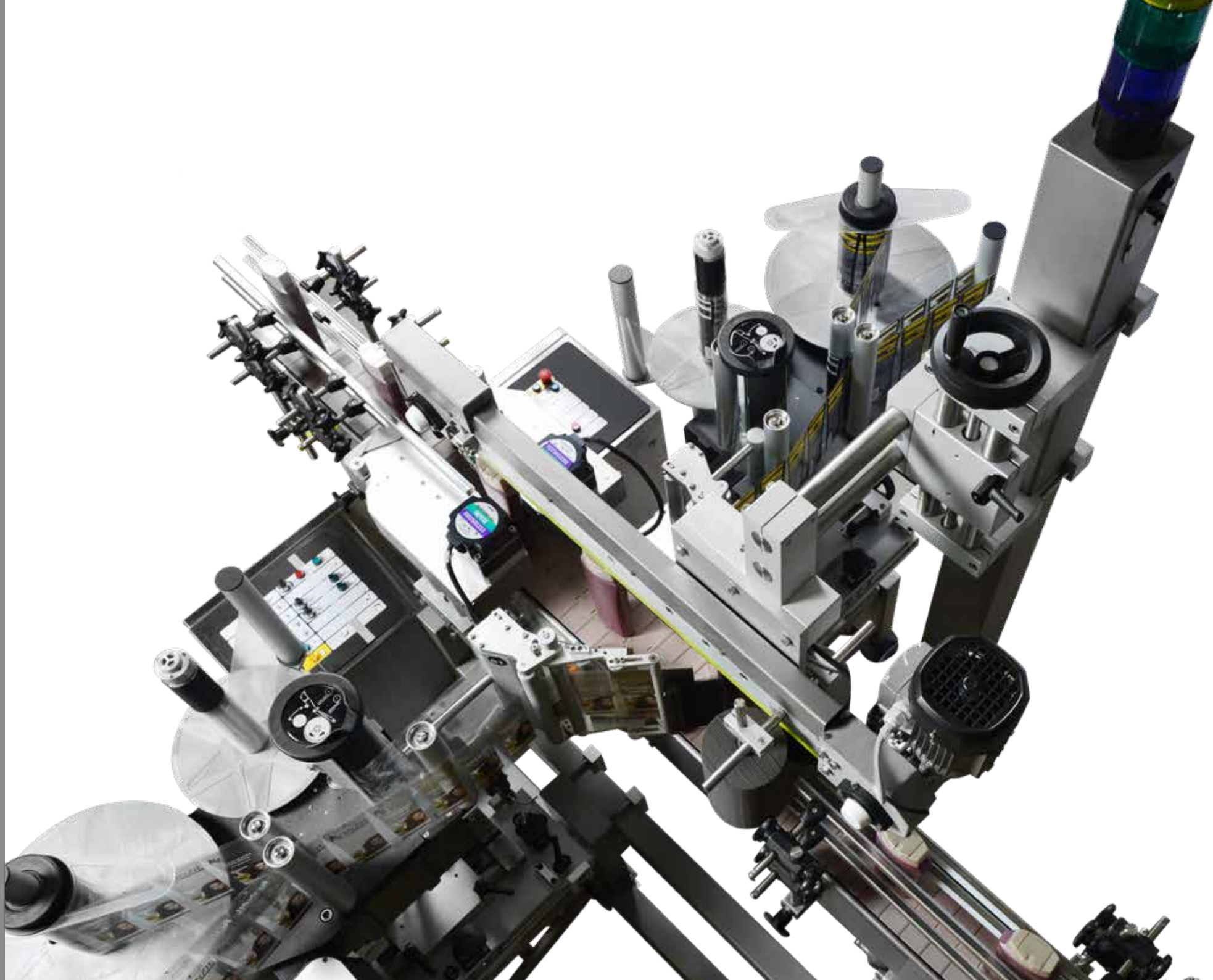





TWO SIDES

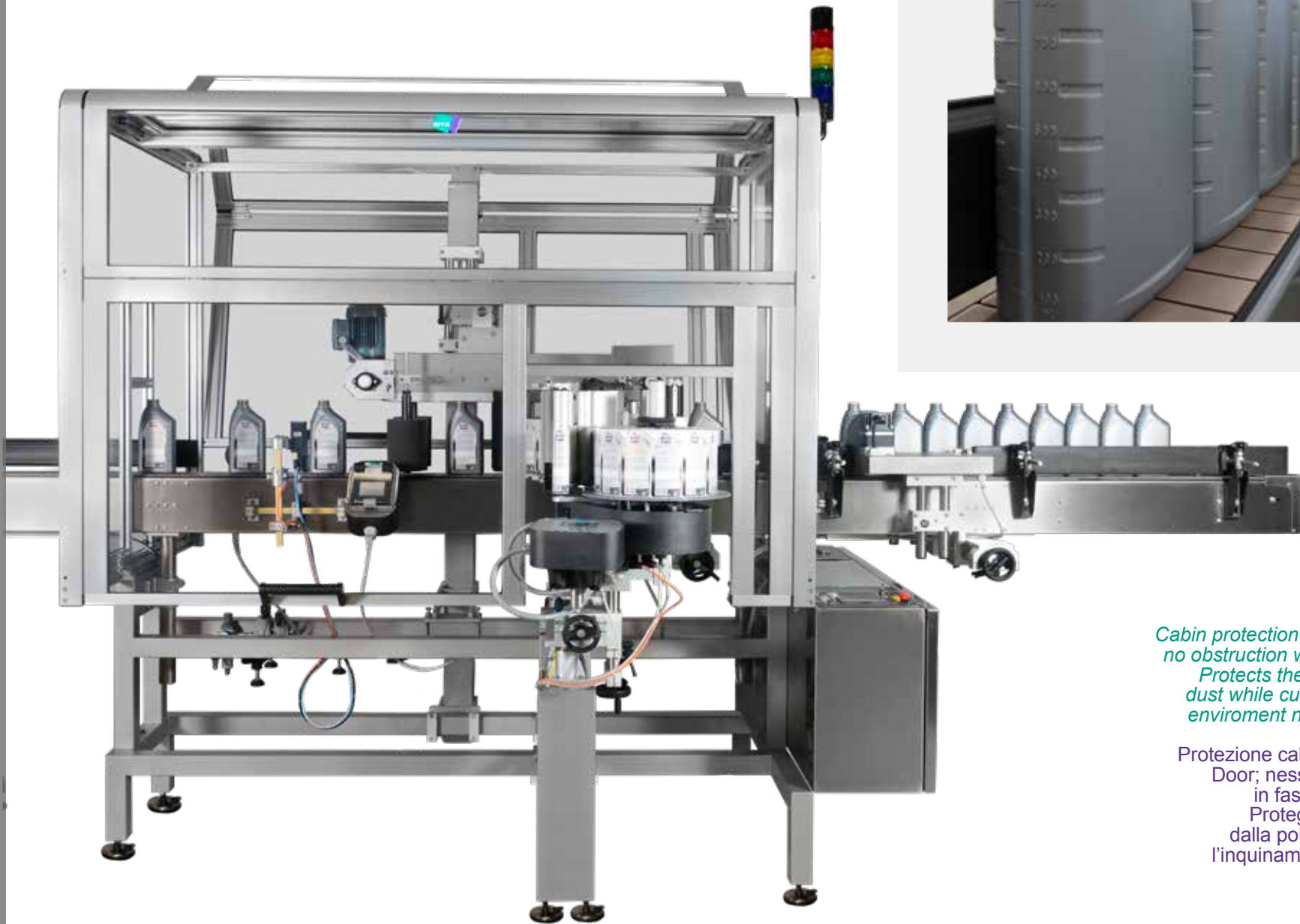
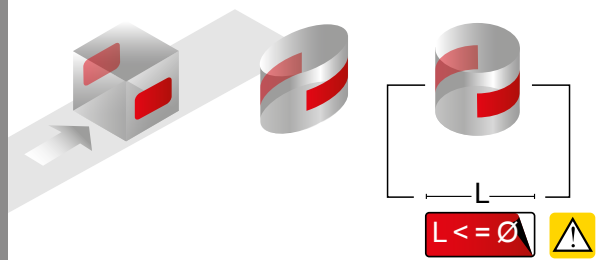

*Cabin protection Sliding Door;
no obstruction when opened.
Protects the system from
dust while cutting down on
environment noise pollution*

Protezione cabinata Sliding
Door; nessun ingombro
in fase di apertura.
Protegge il sistema
dalla polvere e riduce
l'inquinamento acustico
ambientale

Solid





20

TWO SIDES

Sliding Door protection to avoid any obstruction of the operating area

Protezione Sliding Door per evitare qualsiasi ingombro dell'area operativa

The system can be configured with or without Sliding Door protection

Il sistema può essere configurato con o senza protezioni Sliding Door



Solid



Mobil
Super
2000

10W-40

Semi-Synthetic
Motor Oil

Gasoline & Diesel

Mobil
Super
2000

10W-40

Semi-Synthetic
Motor Oil

8197018
1L

Gasoline & Diesel



TWO SIDES

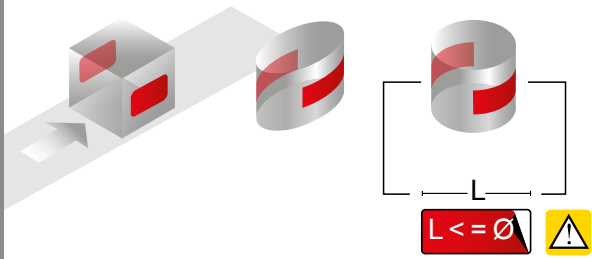

4 labelers in Non Stop configuration
with extraction slides
System with graphic interface with rotating support

4 etichettatrici in configurazione Non Stop
su slitte di estrazione
Sistema con interfaccia grafica su supporto brandeggiante



Solid
Hightech



Large independent electrical system cabinet with external ethernet door, electrical service socket, internal lighting

Ampio impianto elettrico indipendente con porta ethernet esterna, presa elettrica di servizio, illuminazione interna

Protection system using sliding doors (no aisleway clearance requirements) with the labeler on a slide, totally accessible, facilitating roll changes with the machine in operation

Protezione ad ante scorrevoli (nessun ingombro del corridoio) con etichettatrici su slitta totalmente accessibili, per agevole sostituzione rotolo a macchina funzionante

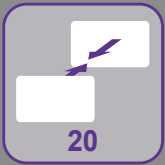

TWO SIDES



**Solid
Hightech**

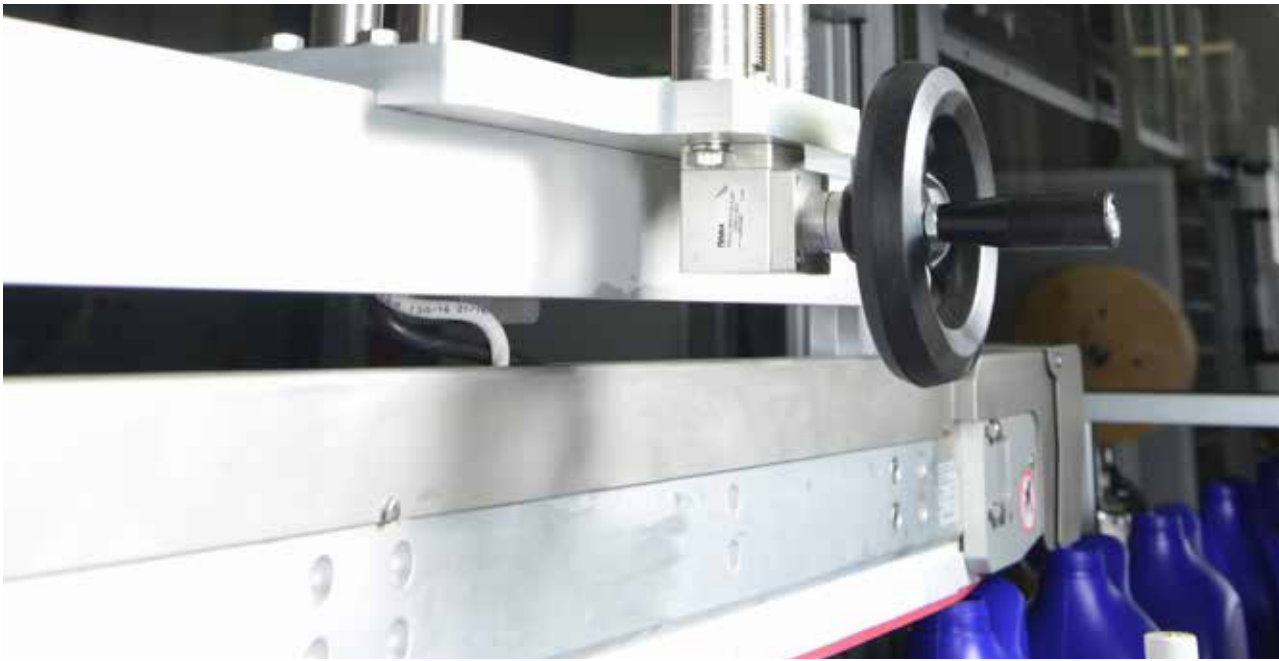

Ergonomic regulation of the upper stabilizer (from the operator side)

Regolazione ergonomica dello stabilizzatore superiore (dal lato operatore)



Actual label application check and ejector with air blower or pneumatic cylinder

Controllo avvenuta etichettatura ed espulsore a soffio d'aria o a cilindro pneumatico



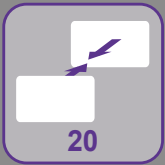

TWO SIDES

The adapters attached to the upper stabilizer do not require adjustment to the format change



Gli adattatori fissati allo stabilizzatore superiore non richiedono regolazione al cambio formato



NON STOP

400
pcs/min



Hightech Non-Stop systems, with productivity of more than 350 pieces per minute, are an ideal alternative to rotary labeling systems: with faster format changes with no parts to replace. Perfect for chemistry and toiletries

I sistemi Hightech Non Stop, con una produttività superiore a 350 pezzi al minuto, rappresentano un'alternativa ideale ai sistemi di etichettatura rotativa: con cambi formato più rapidi e senza parti da sostituire. Perfetti per la chimica e la toiletries

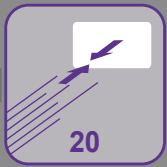

TWO SIDES

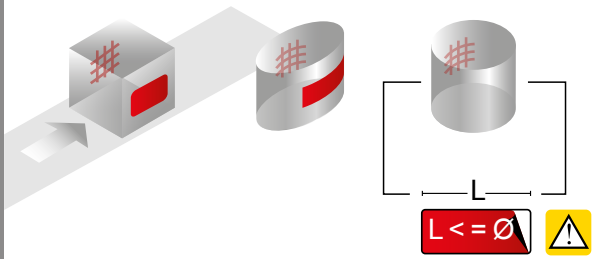

*System with 1 fiber laser marker
and 1 labeler*

*Sistema con 1 marcatore Fiber
laser e 1 etichettatrice*

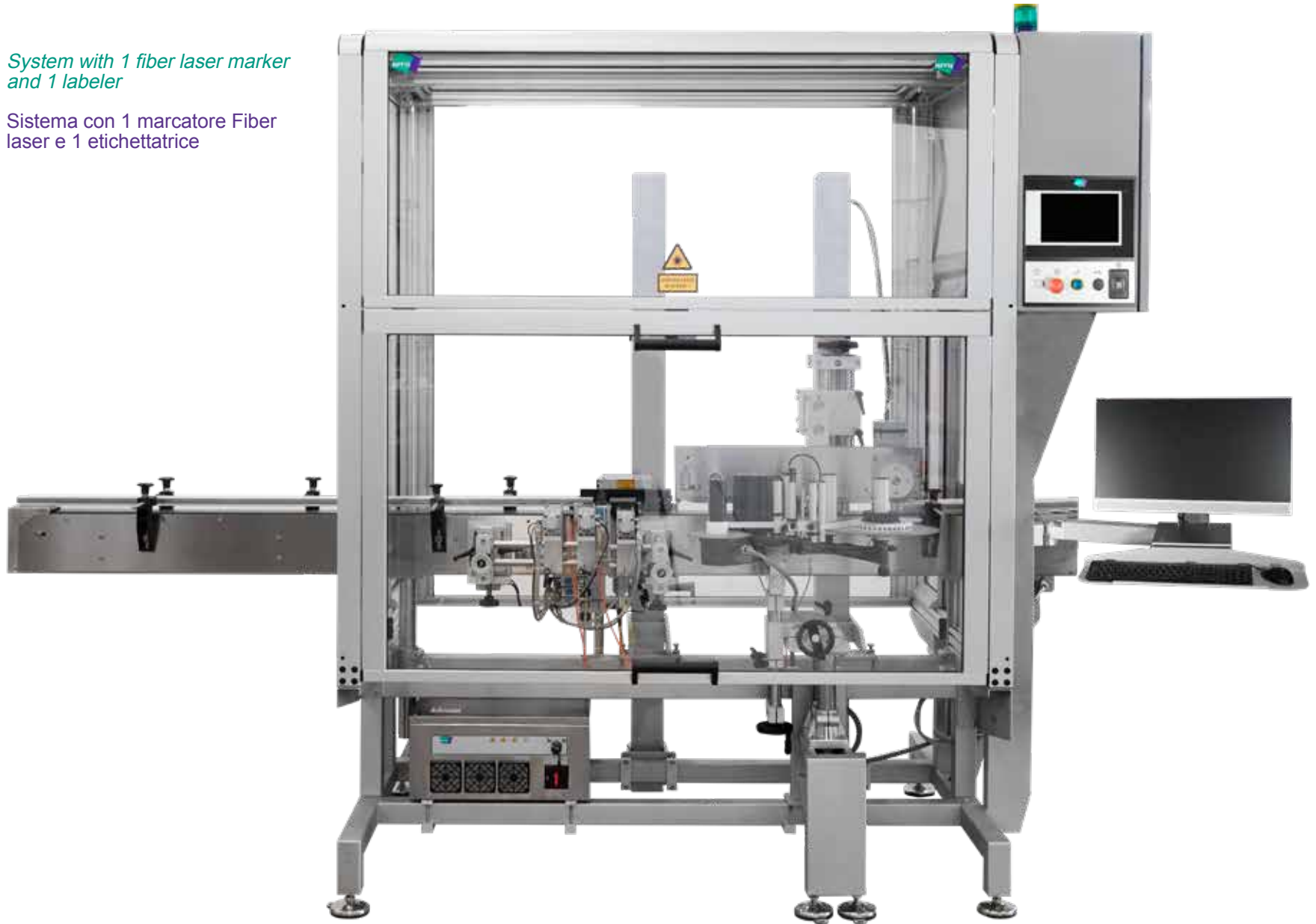

*Localized part protection
during laser marking*

RADIAZIONE LASER
EVITARE L'ESPOSIZIONE AL LASER
E DELLA VISTA ALLA RADIAZIONE
DIRETTA E DIFFUSA
LASER DI CLASSE II

Protezione localizzata del pezzo
durante la marcatura laser

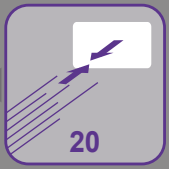

TWO SIDES







23.1

FRONT-R & TOP rotating

Solid

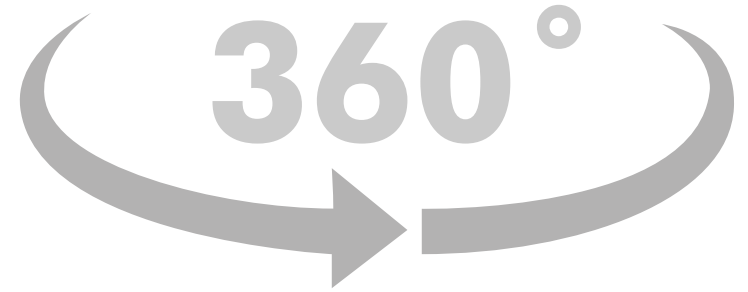
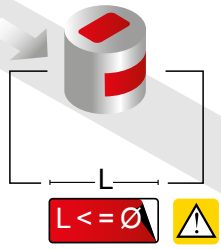

After Top labeling (1), the angular positioner turns the product (2), allowing the application of the Front label, laterally (3) and at a specific point on cylindrical product. The rotation angle can be stored in the appropriate "product" program to speed up the set up

Dopo l'etichettatura Top (1), il posizionario angolare ruota il prodotto (2), consentendo l'applicazione dell'etichetta Front, dal lato (3) e in un punto specifico del prodotto cilindrico. L'angolo di rotazione può essere memorizzato nell'apposito programma "prodotto" per velocizzare il set up



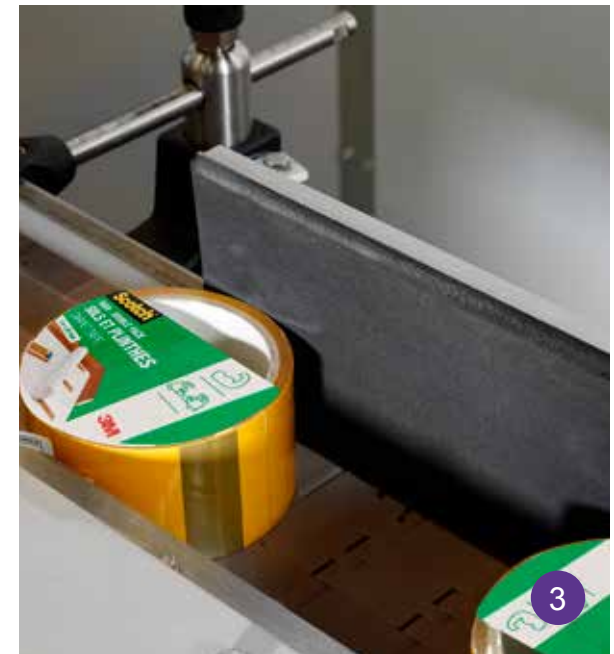

The Arca angular positioner orients your products to apply each label to the right place, just where you want it

Il posizionatore angolare di Arca orienta i vostri prodotti per applicare ogni etichetta al posto giusto, proprio dove voi la volete



TOP & BASE

Solid



*2 print apply labelers
with HPS applicator (Top) with pad rapid
coupling and rigid peeler (Base)
Conveyor in two independent sections for
better working during reel change*

*2 etichettatrici print apply con applicatore
HPS (Top) dotato di innesti rapidi della piastra
e staccatore rigido (Base)
Convogliatore in due sezioni indipendenti per
la migliore operatività durante il cambio rotolo*

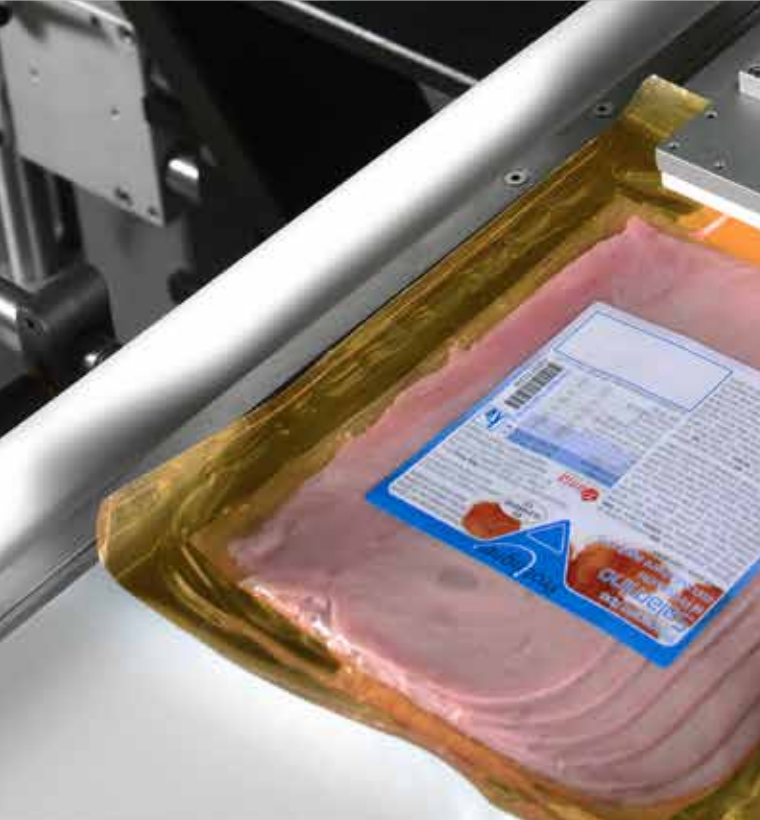
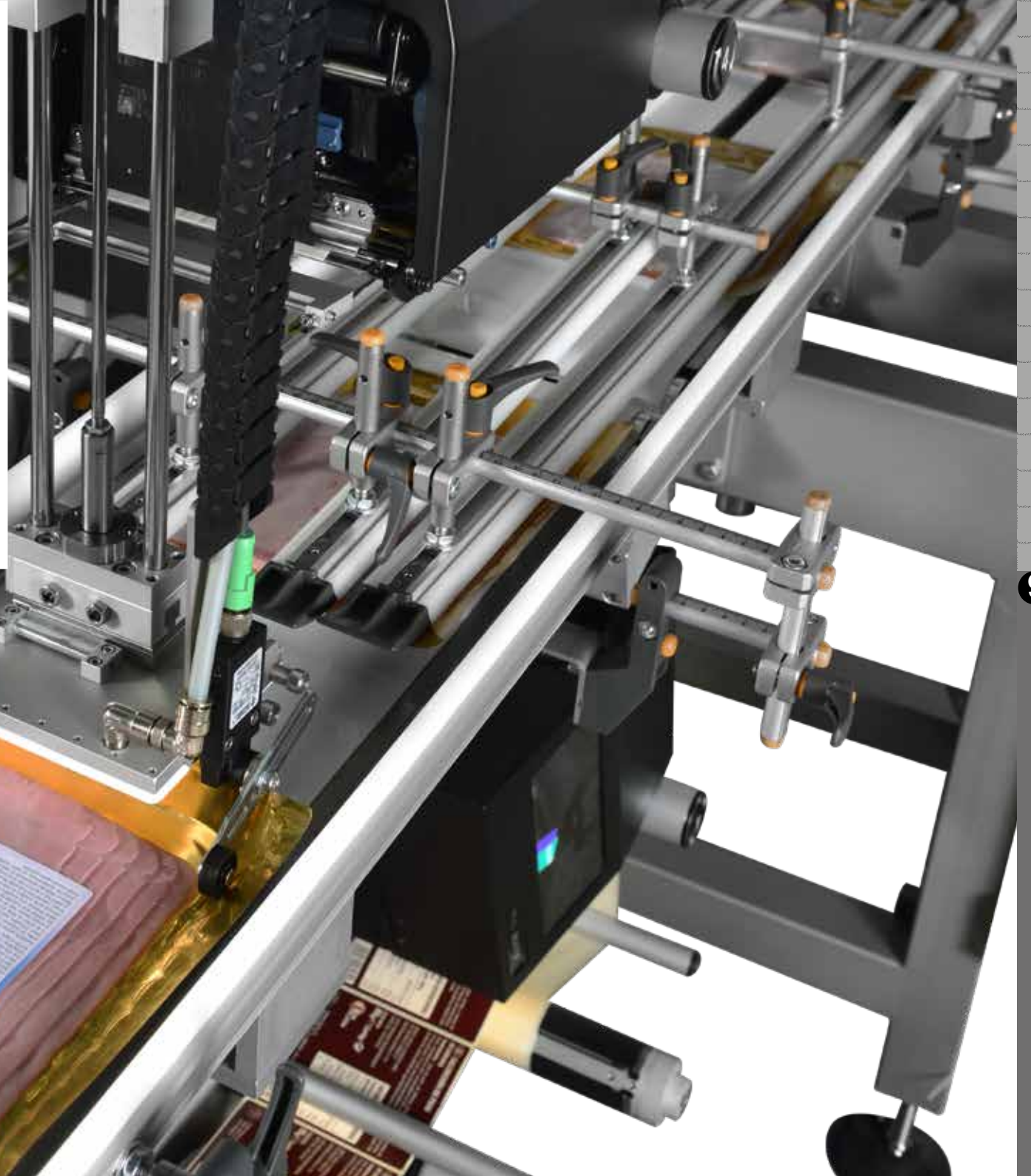
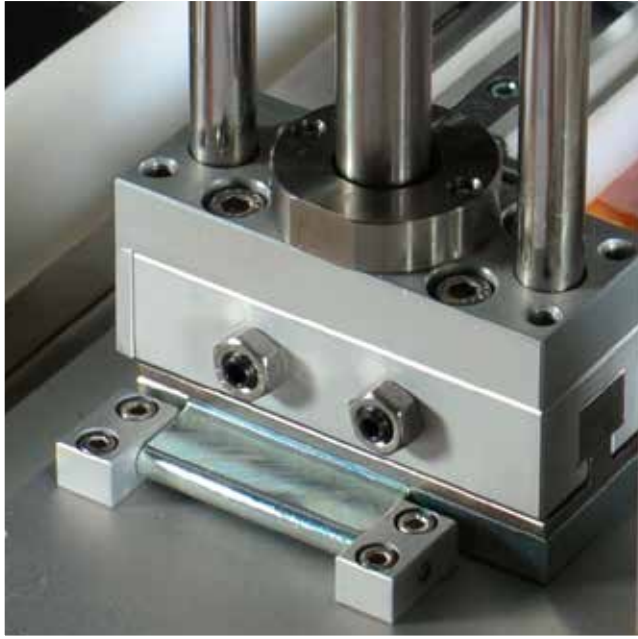



TOP & BASE

Solid

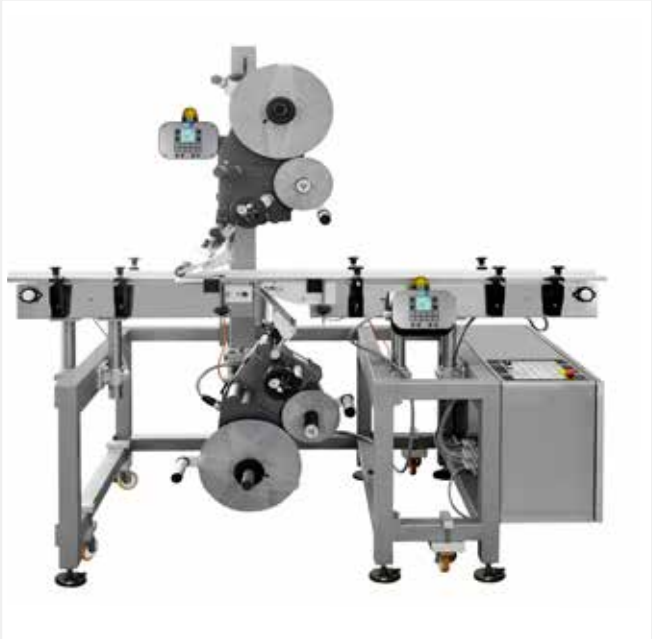





SIDE & WRAP DOWN indexed

Solid

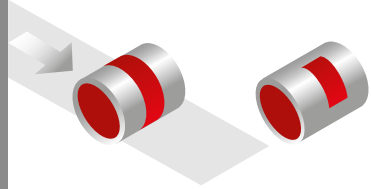

The products access has a movable guard for maximum safety

L'ingresso prodotti prevede una protezione mobile per la massima sicurezza

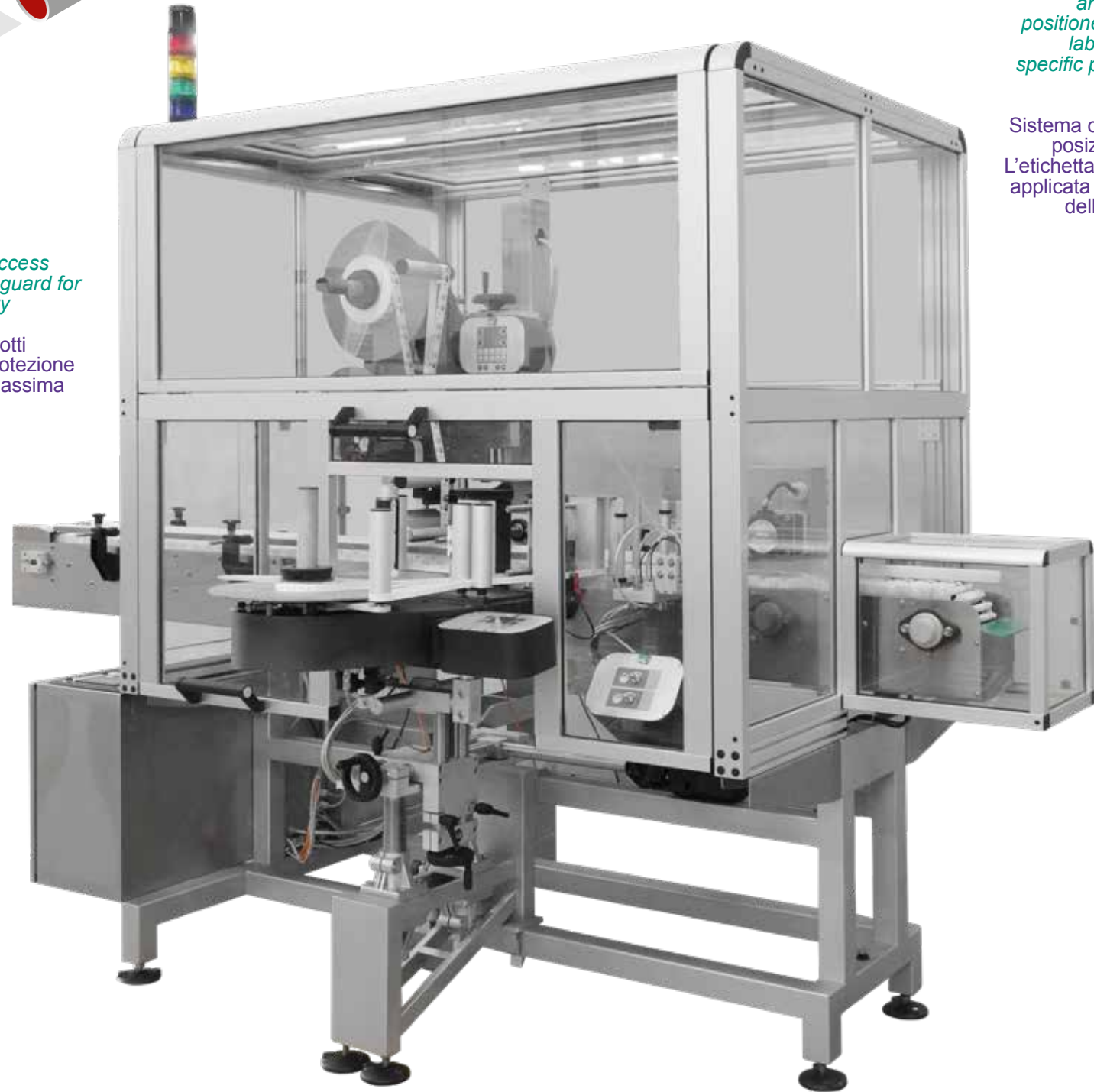

System with 2 labelers and indexed labeling. positioner The wrap around label is positioned in a specific point on the product circumference

Sistema con 2 etichettatrici e posizionario a registro. L'etichetta wrap around viene applicata in un punto preciso della circonferenza del prodotto





TWO SIDES & TOP

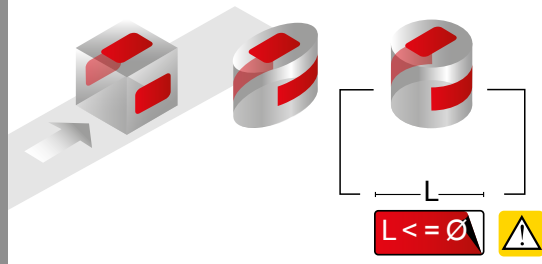



*HPS applicator for
Top labeling on hollowed
surfaces*

Applicatore HPS per
etichettatura Top su sedi
incavate



40.22

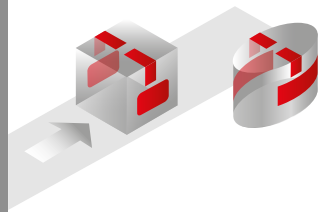

The Hightech Non Stop system coordinates two labelers placed in line, ensuring functional continuity. Labelers are always fully accessible and they are automatically extracted (controlled motion) when the label roll is exhausted. Substitution is made in a safe situation without need of opening the guards. After reinstatement, the machine is put automatically back into the correct position for functioning



Il sistema Hightech Non Stop coordina due etichettatrici collocate in batteria, garantendo la continuità di funzionamento. Le etichettatrici sono sempre perfettamente accessibili e vengono estratte automaticamente (moto controllato) all'esaurimento del rotolo etichette. La sostituzione viene effettuata in sicurezza senza necessità di apertura delle protezioni. Dopo il ripristino la macchina viene riportata automaticamente nella posizione corretta per il funzionamento

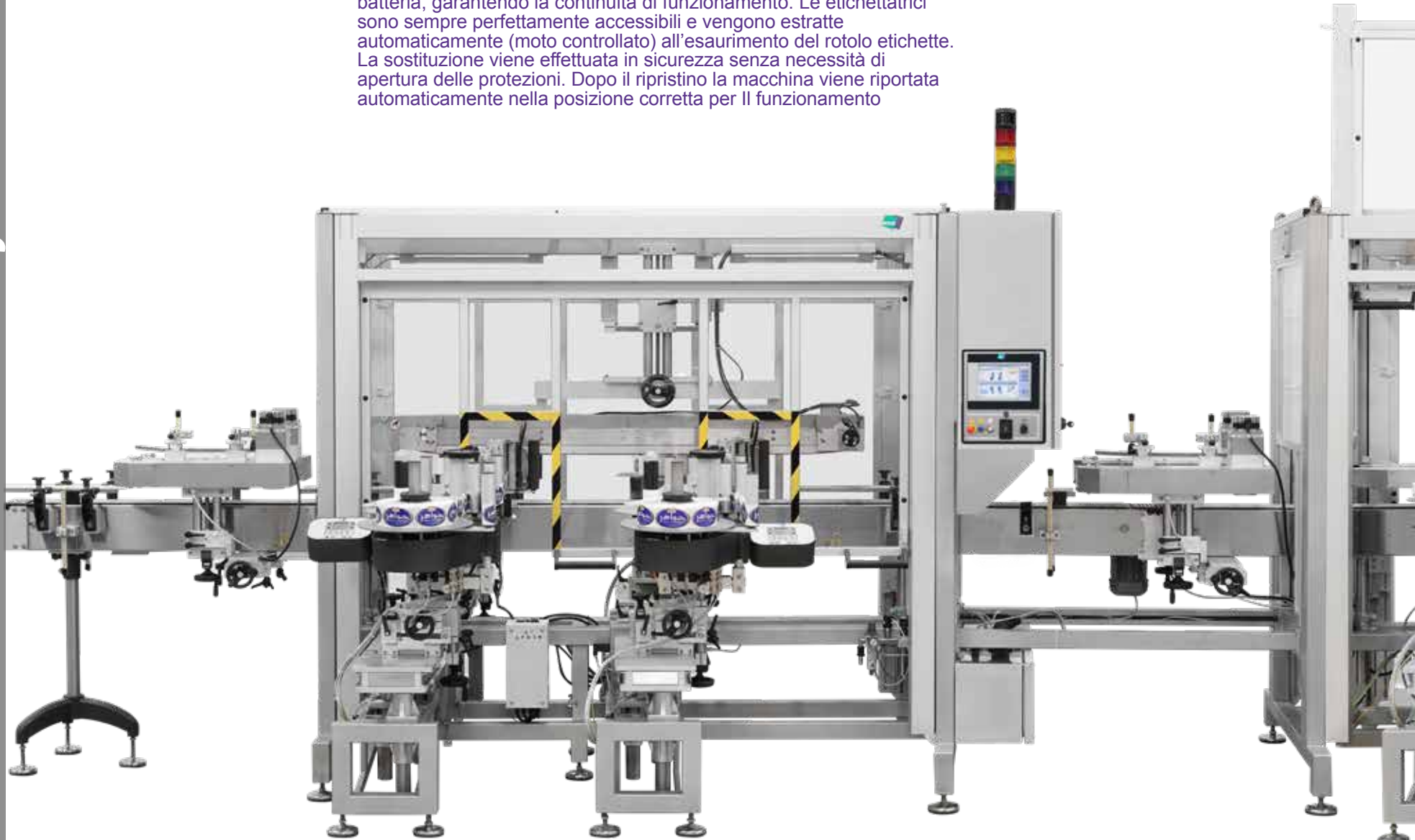

TWO SIDES & SIDE TOP
body & seals

**Solid
Hightech**



Protection system using vertically Sliding Door (no aisleway clearance requirements)

Protezione Sliding Door ad ante scorrevoli verticalmente (nessun ingombro del corridoio)

Independent station of inspection and ejection of incorrect products

Stazione indipendente di ispezione ed espulsione prodotti errati

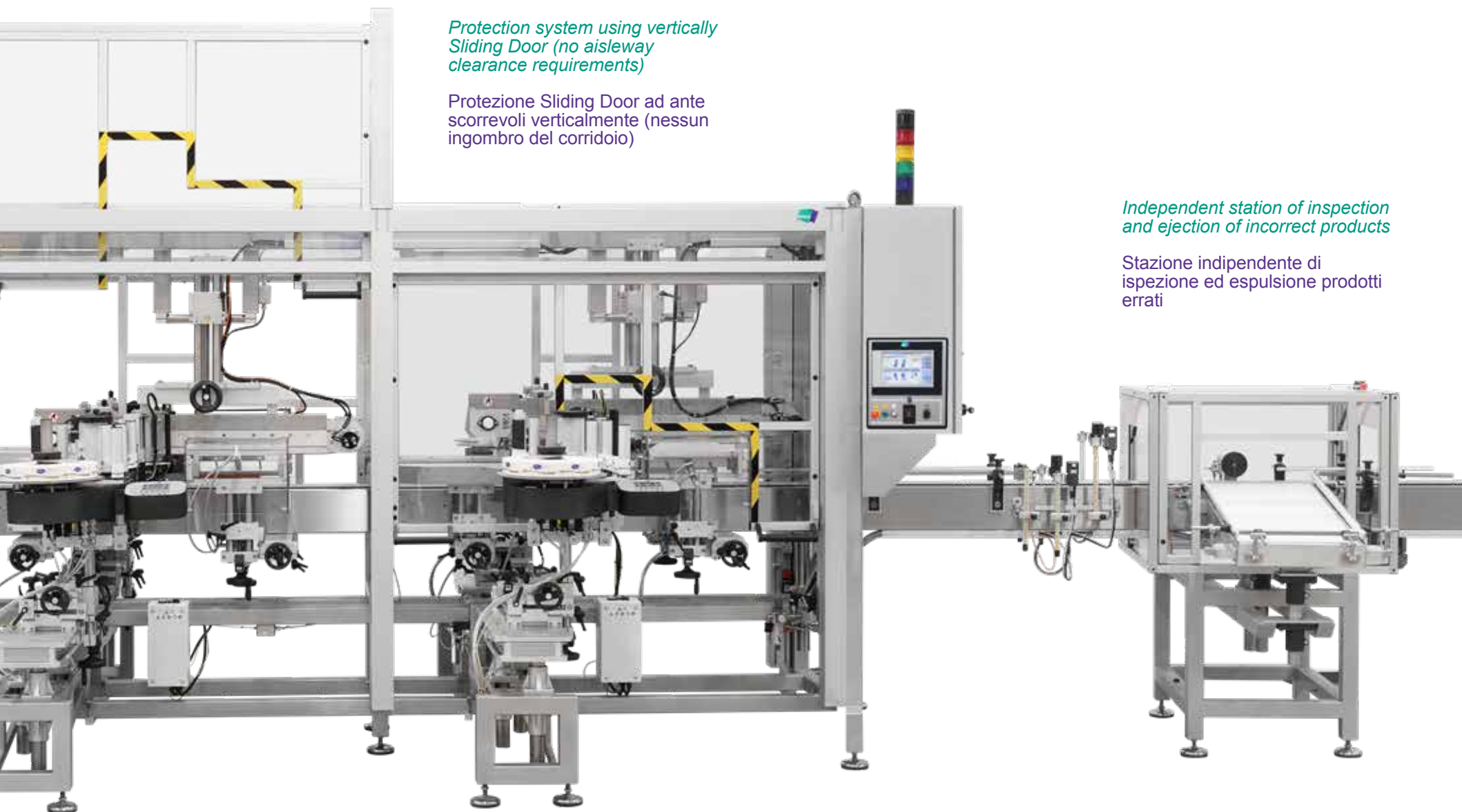



40.22

TWO SIDES & SIDE TOP *body & seals*

Solid
Hightech

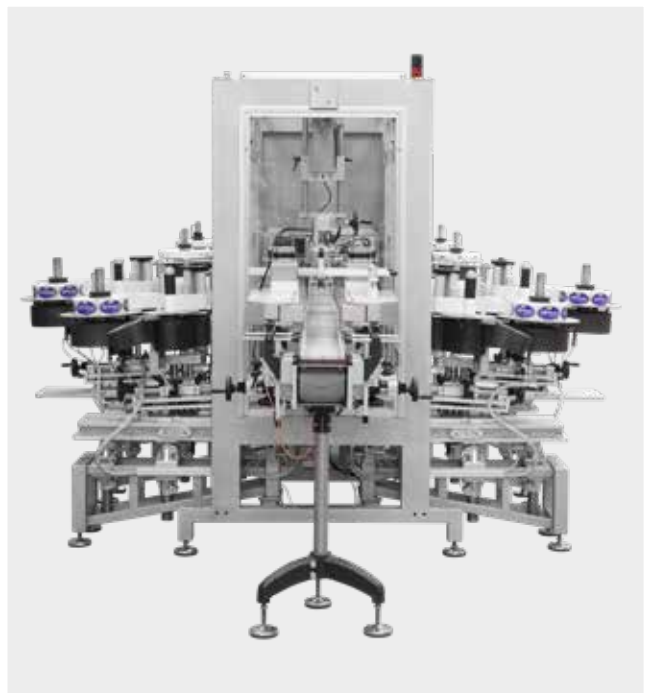

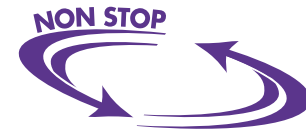

*Side L-Seal adapters bi-directional dynamic roller.
They work on sloped surfaces too and include fine
adjustment*

Adattatori Seal-L Side a rullo dinamico
bidirezionale.
Funzionano anche su superfici inclinate e sono
dotate di regolazione fine

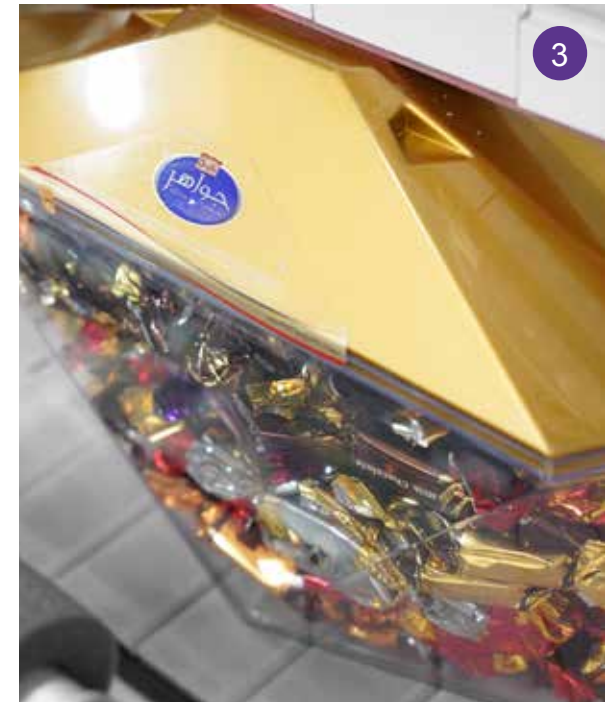
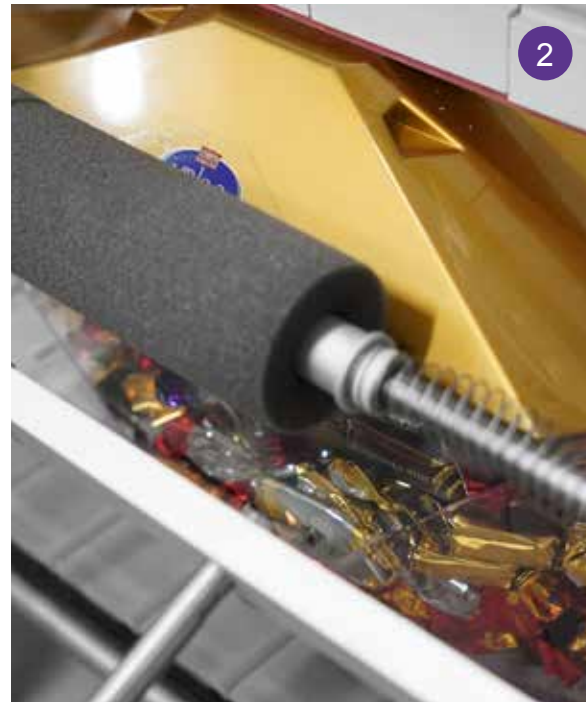



10



11



11.2

COMBI



20



22.2

*A single Combi system with 2 labelers and thermal transfer digital print module, allows to apply labels on various sides of many different products.
Switching between applications is done without any component replacement*

Un unico sistema Combi con 2 etichettatrici e modulo di stampa digitale a trasferimento termico, consente di effettuare applicazioni su vari lati di molti prodotti diversi. Il passaggio da un'applicazione all'altra, si effettua senza alcuna sostituzione di componenti

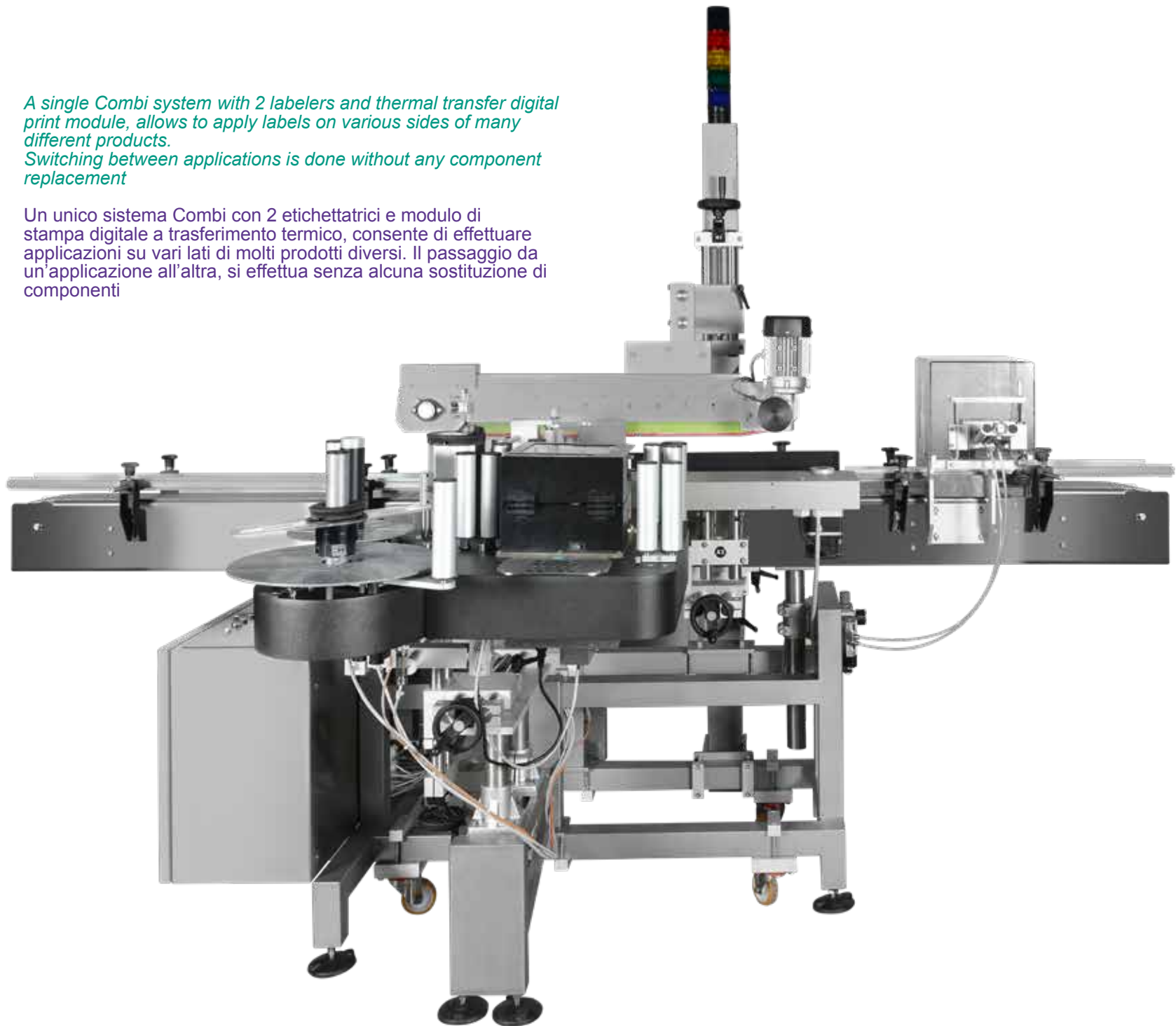

Solid

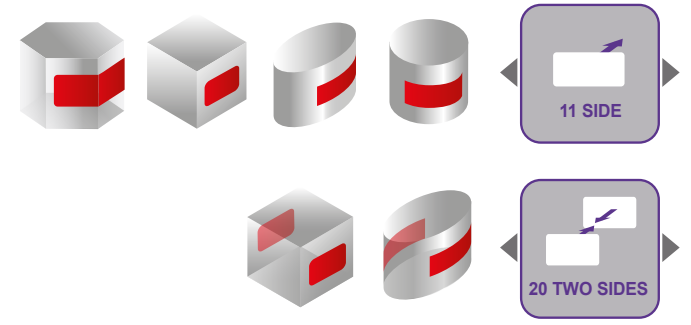
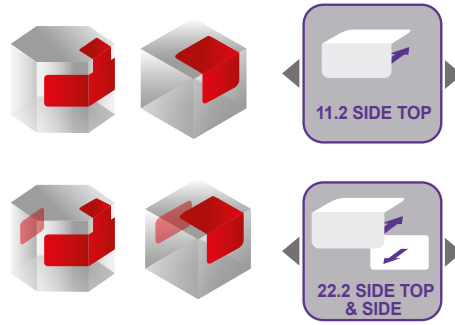

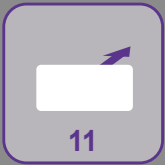

11

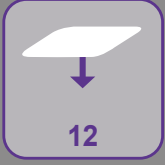

12

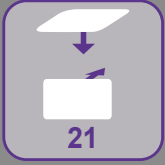

21

COMBI



21.1



21.2



21.4

Solid

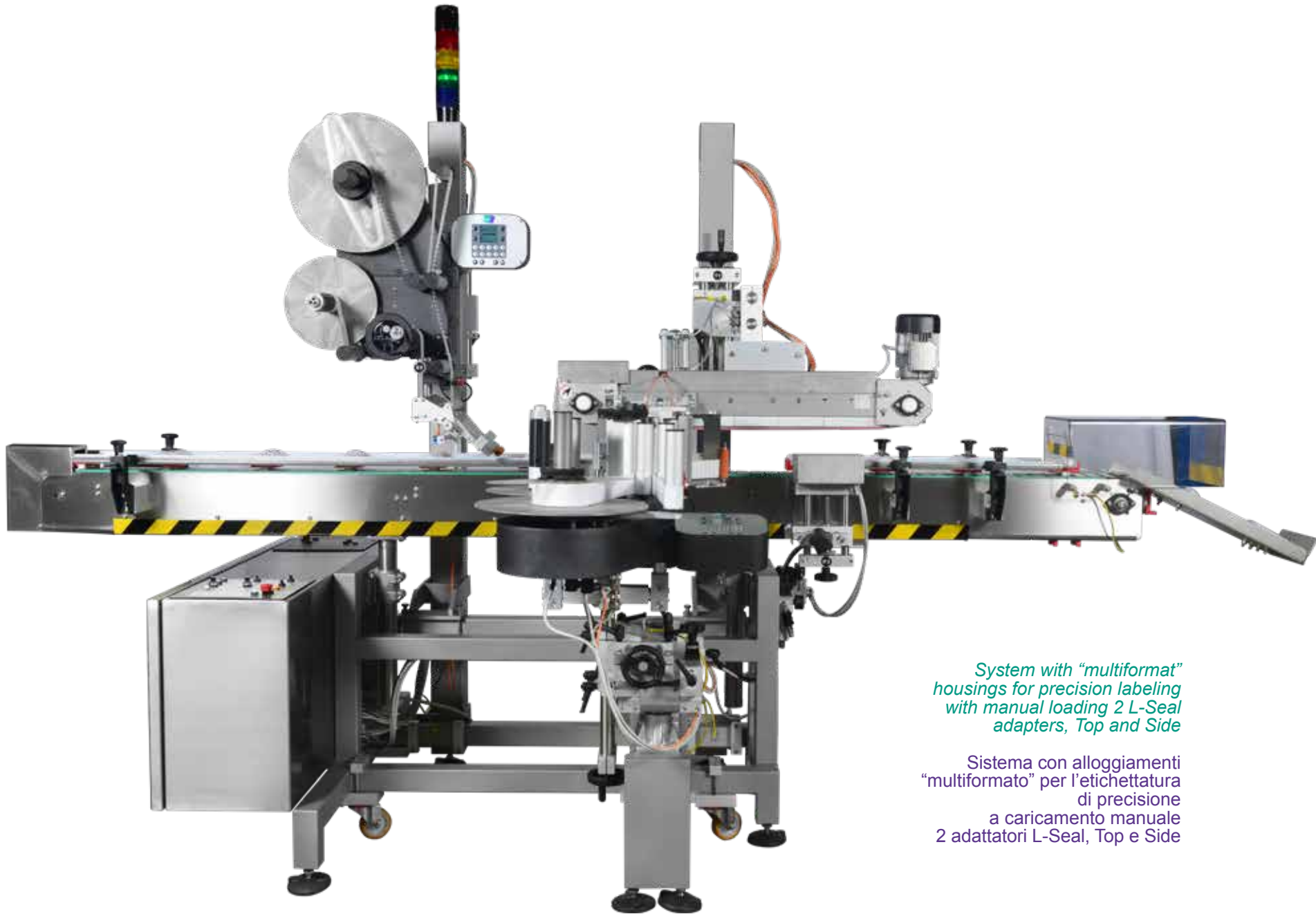

*System with "multiformat"
 housings for precision labeling
 with manual loading 2 L-Seal
 adapters, Top and Side*

Sistema con alloggiamenti
 "multiformato" per l'etichettatura
 di precisione
 a caricamento manuale
 2 adattatori L-Seal, Top e Side

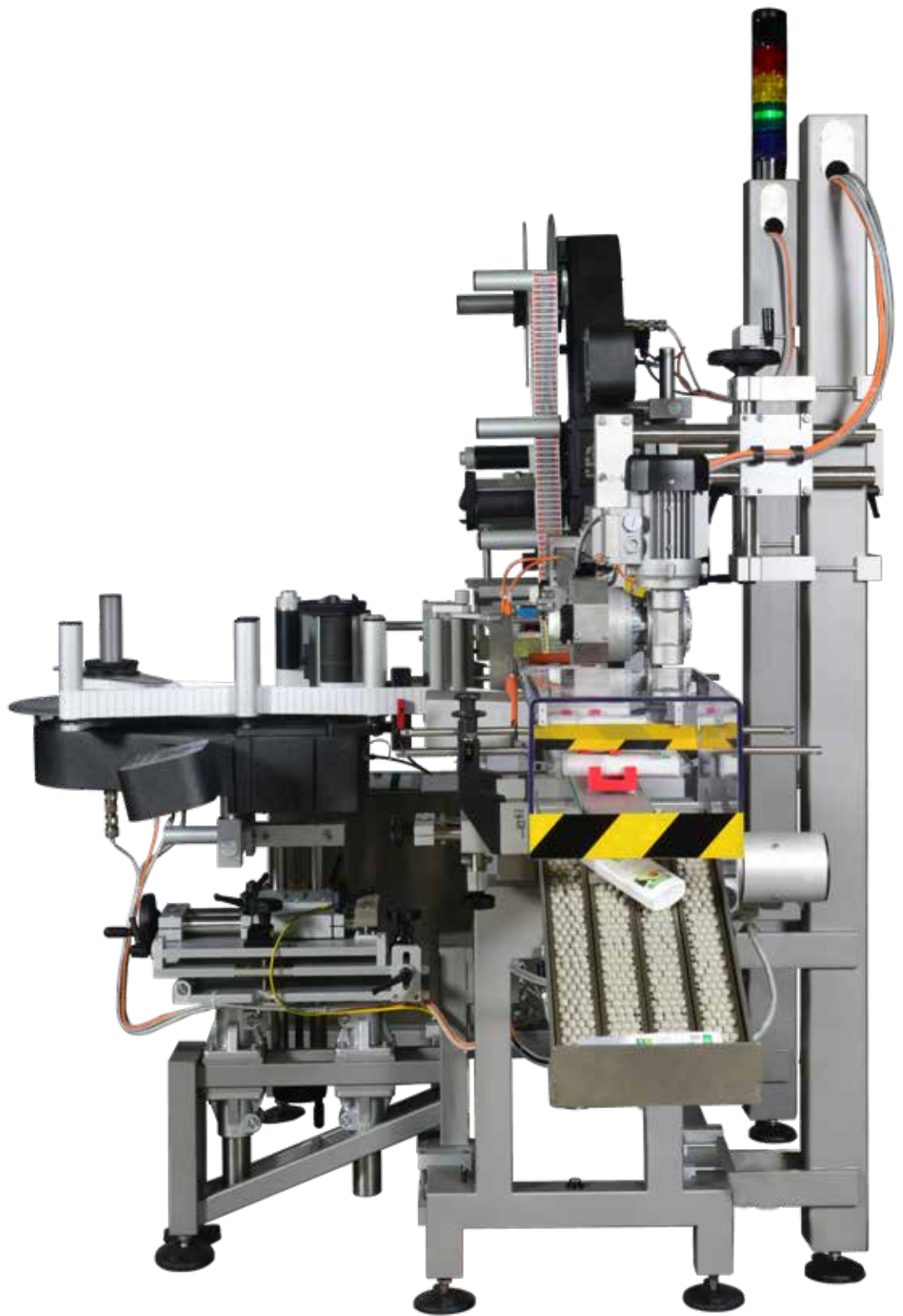

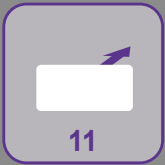

11

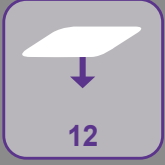

12

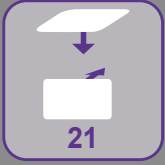

21

COMBI



21.1



21.2



21.4

Solid



Top



Top Side
& Side Top



Top Side
& Side Base

Cartons do not require specific housings; the cartons are placed directly onto the conveyor and simply pushed forward by the housing supports

Gli astucci non richiedono alloggiamenti specifici; vengono movimentati in appoggio ai supporti degli alloggiamenti stessi



Side Top



Side Top



SPECIAL CONVEYORS

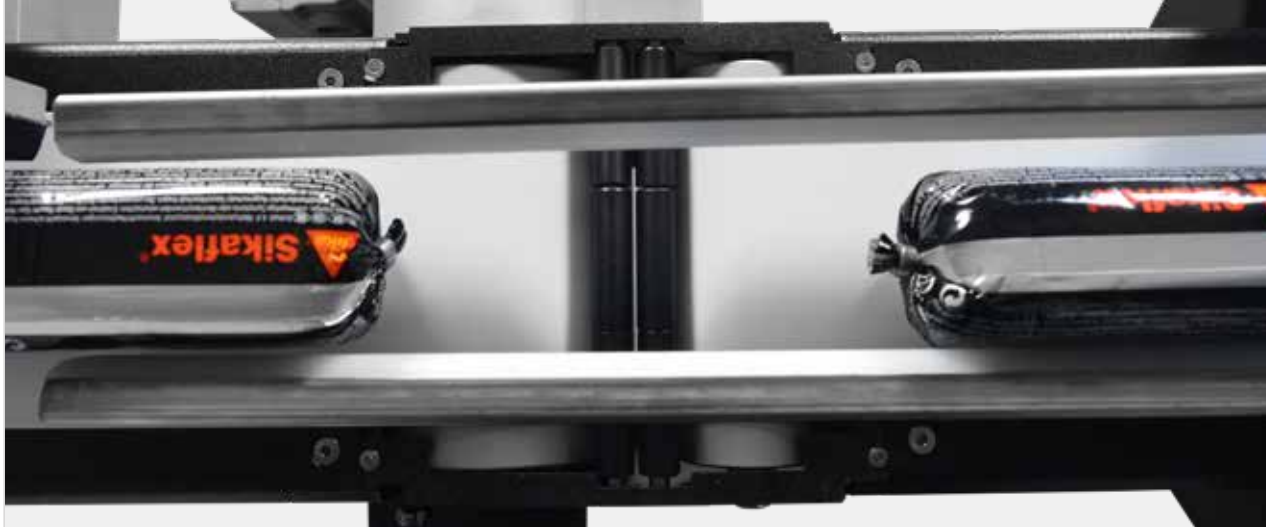

First section independent of conveyor, with the possibility of products spacing and automatically inverting the feed to expel defective products

Prima sezione indipendente del convogliatore, con possibilità di distanziamento prodotti e inversione automatica del moto per espulsione prodotti difettosi

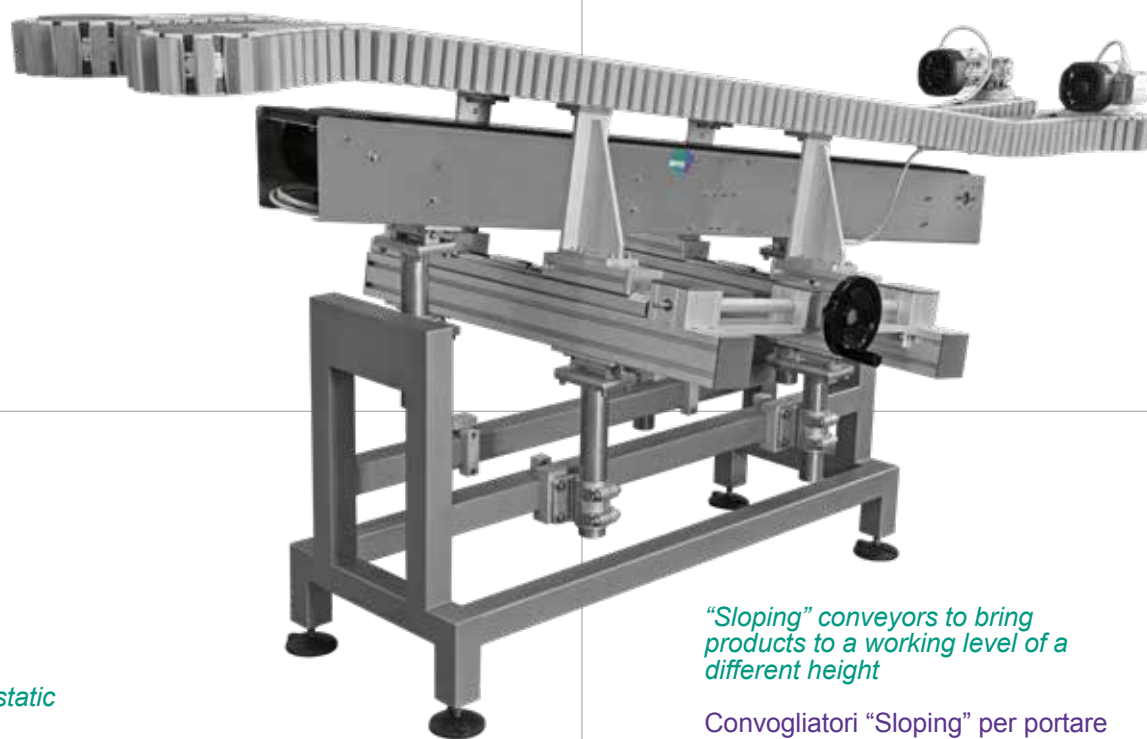

“Sloping” conveyors to bring products to a working level of a different height

Convogliatori “Sloping” per portare i prodotti ad un piano di lavoro avente quota differente



Conveyors with anti static transport chains

Convogliatori con catene di trasporto antistatica

“Multiformat” housings for precision labeling with manual loading systems. You can house several similar products in the same housing, reducing time for format change

Alloggiamenti “multiformato” per l’etichettatura di precisione con sistemi a caricamento manuale. E’ possibile alloggiare più prodotti simili, nel medesimo alloggiamento, riducendo i tempi di cambio formato



SEAL ADAPTERS



The seals can also be adapted on the Top of the product after the label has been applied to the product Side

L'adattamento dei sigilli può essere effettuato anche sul lato superiore (Top) dopo che l'etichetta è stata applicata sul lato del prodotto (Side)

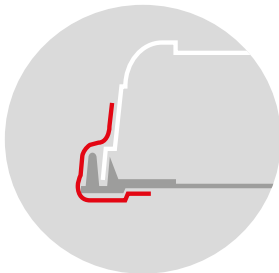

Special adapters for irregular profiles

Adattatori speciali per sagome irregolari



Top pneumatic adapters for "U" seals (low speed). An efficient solution, able to adapt even on very wide products

Adattatori pneumatici Top per sigilli a "U" (bassa velocità). Una soluzione efficiente, in condizione di adattare anche su prodotti molto larghi



Additional back brush adapter

Adattatore aggiuntivo back a spazzola



Top pneumatic adapters for “U” seals. They adapt the label (medium size too) on the vertical sides and at the same time shift horizontally to suit the product’s movement

Adattatori pneumatici Top per sigilli a “U”.
Adattano l’etichetta (anche di medie dimensioni) sui lati verticali e, contestualmente, traslano orizzontalmente per assecondare il movimento del prodotto

SPECIAL BASES

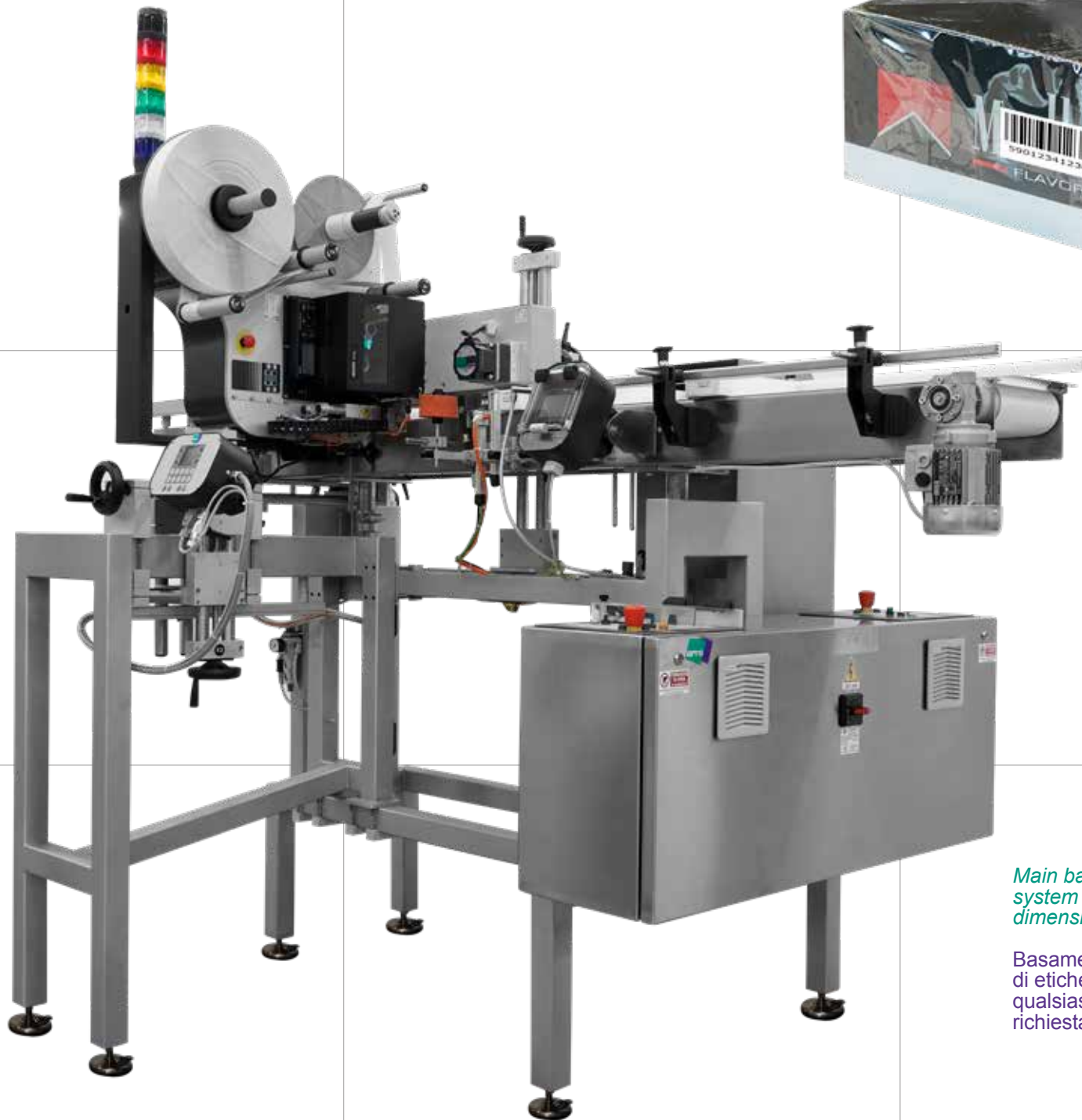

Main bases for labeling system having any dimension on demand

Basamenti per sistemi di etichettatura con qualsiasi dimensione a richiesta



Independent ejection station

Stazione di espulsione indipendente



Base print apply in Side configuration for Solid systems

Basamento per print apply in configurazione Side su sistemi Solid

OTHER DEVICES



Vision sensor for "actual labeling" check

Sensore di visione per il controllo "avvenuta etichettatura"



Vision sensor visor with metal housing. It is needed only for systems without industrial pc

Visore del sensore di visione con alloggiamento metallico. Necessario solo per i sistemi privi di pc industriale

"Air blast" product ejector with "actual rejection" check

Espulsore prodotti "a soffio d'aria" con controllo "avvenuta espulsione"

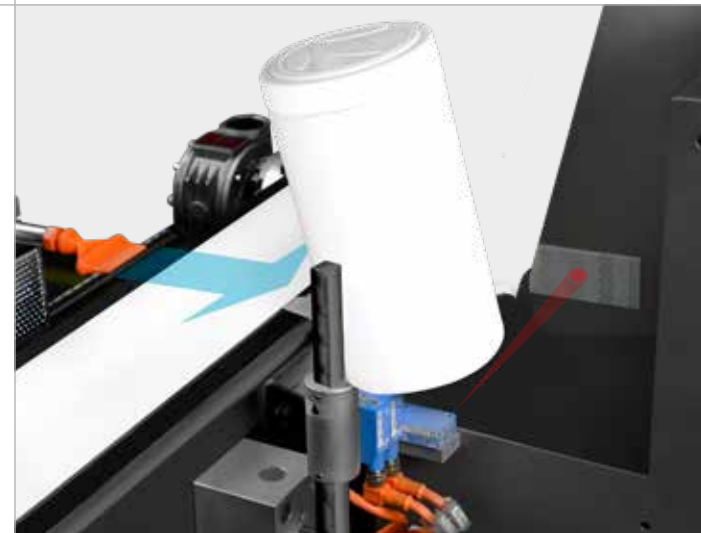



*Collection bin for ejected products.
Made in AISI 304 stainless steel; equipped
with rubber floor covering (removable) and a
transparent polycarbonate shutter with a key
opening and safety hinges*

Contenitore di raccolta "prodotti espulsi".
Realizzato in acciaio inossidabile AISI 304;
dotato di rivestimento in gomma sul fondo
(amovibile) e sportello in policarbonato
trasparente con apertura a chiave e cerniere di
sicurezza



*Fine tuning of the tilting on two axes.
For modifying the tilting of the labeler in lateral
position, via handles and numerical position
indicators (it doesn't require the employment of
tools).*

*It's ideal for easy and precise adjustment at the
"format change" stage and can also be actioned
during operation.*

*Essential for labeling around conical products; also
useful however for the Side labeling of non conical
products*

Regolazione fine dell'inclinazione su due assi.
Per modificare le inclinazioni dell'etichettrice in
posizione laterale, mediante manopole ed indicatori
numerici di posizione (non necessita l'impiego di
utensili).

E' ideale per una regolazione agevole e precisa in
sede di "cambio formato" ed è azionabile anche
durante la lavorazione.

Indispensabile per l'etichettatura su prodotti conici;
comunque utile anche per l'etichettatura Side di
prodotti non conici

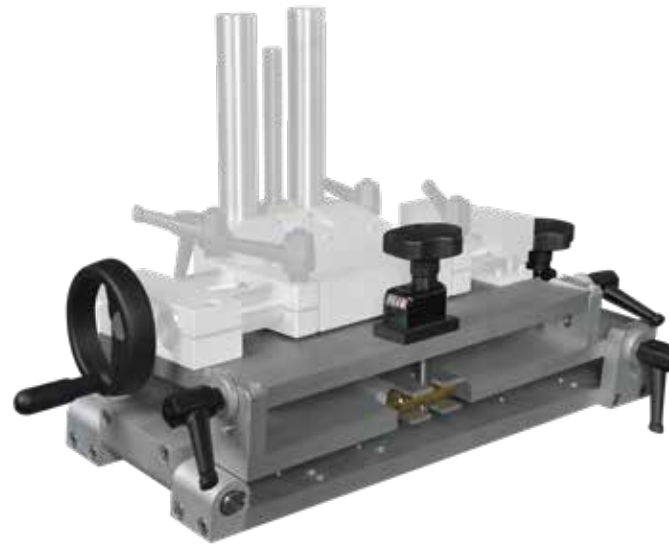

*The sensor supports are made with strong anti
rotation (square sectioned) millimetric rods to avoid
any accidental readjustment*

I supporti dei sensori sono realizzati con robuste
aste millimetriche antirotazione
(a sezione quadrata) per evitare qualsiasi
sregolazione casuale



*Check for correct product positioning
Controllo corretto posizionamento prodotto*

*Pneumatic cylinder ejector
Espulsore a cilindro pneumatico*



Specialized systems to go through a specific task:

- *Wrap Around 110-160*
- *Striped Linerless 5000*
- *Converter*
- *Feeder*
- *Card Board*
- *Pharma Seal 4.0*

Specialized *Labeling Systems*

Sistemi specializzati per svolgere al meglio un compito mirato:

- **Seal/Top/Base 110 semi-automatic**
- **Wrap Around 160 semi-automatic**
- **Striped Linerless 5000**
- **Converter**
- **Feeder**
- **Card Board**
- **Pharma Seal 4.0**





System for semi-automatic labelling (manual package handling) of parallelepiped products. It allows the application of a 'seal' label on two adjacent sides. Or a label on the front or back, depending on how the product is loaded



Seal/ Top/ Base semi-automatic

110

Sistema per l'etichettatura semiautomatica (movimentazione della confezione manuale) di prodotti parallelepipedi. Consente l'applicazione su due lati adiacenti di un'etichetta "sigillo". Oppure di un'etichetta sul fronte o sul retro, in funzione della modalità di caricamento del prodotto



And, loading the overturned product...

E, caricando il prodotto ribaltato...



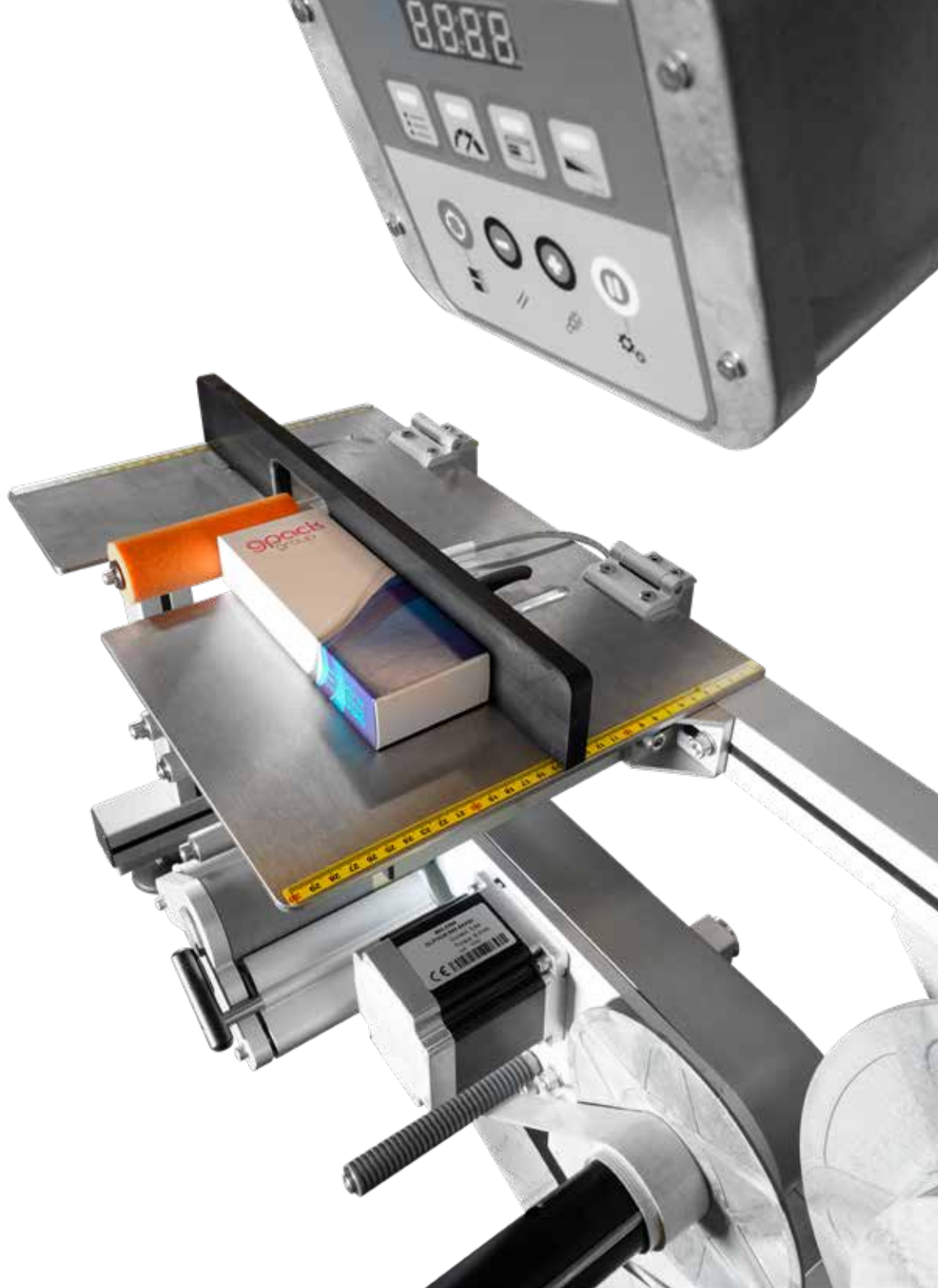

119

Seal/Top/Base 110

A system for the semi automatic labeling (loading and unloading by hand) of cylindrical products. It allows for even wrap around application of one front label or two labels front and back (printed on the same reel). Otherwise it can apply one indexed label

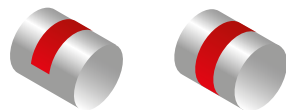

Wrap Around semi-automatic

160

Sistema per l'etichettatura semiautomatica (carico e scarico manuale) di prodotti cilindrici. Consente l'applicazione anche avvolgente di un'etichetta fronte, o due etichette fronte e retro (stampate sullo stesso rotolo). Oppure applicazione di un'etichetta "a registro"



Available from June 2023
Disponibile da Giugno 2023

"Front" and "back" labels
on the same silicon liner

Etichette "fronte" e "retro"
sullo stesso supporto
siliconato

From the gorgeous lemon groves of Southern Italy, comes **CARAVELLA LIMONCELLO** created from an original family recipe dating back to 1898, this combination of lemon juice, lemon peels and the finest grain spirits has become the drink rave of Europe. Taste the flavour of Rome, the excitement of Venice, the beauty of Florence. Salut!

CARAVELLA LEMON MARTINI
1 part Caravella Limoncello
3 parts Vodka
Shake with ice; strain and pour into martini glass. Garnish with lemon strip.

CARAVELLA AND CREAM
1 part Caravella Limoncello
2 parts Cream
Combine in a shaker. Shake well and pour into a rocks glass filled with ice. Garnish with a lemon strip.

IMPORTED BY BARTON IMPORTS
CHICAGO, IL • Contains: F.D.&C. YELLOW # 5



0 80660 77605 7

GOVERNMENT WARNING: (1) ACCORDING TO THE SURGEON GENERAL, WOMEN SHOULD NOT DRINK ALCOHOLIC BEVERAGES DURING PREGNANCY BECAUSE OF THE RISK OF BIRTH DEFECTS. (2) CONSUMPTION OF ALCOHOLIC BEVERAGES MAY BE HARMFUL TO YOU AND TO YOUR CHILDREN.



CARAVELLA
limoncello originale
d'Italia imported from Italy

From the gorgeous lemon groves of Southern Italy, comes **CARAVELLA LIMONCELLO** Created from an original family recipe dating back to 1898, this combination of lemon juice, lemon peels and the finest grain spirits has become the drink rave of Europe. Taste the flavour of Rome, the excitement of Venice, the beauty of Florence. Salut!

CARAVELLA LEMON MARTINI
1 part Caravella Limoncello
3 parts Vodka
Shake with ice; strain and pour into martini glass. Garnish with lemon strip.

CARAVELLA AND CREAM
1 part Caravella Limoncello
2 parts Cream
Combine in a shaker. Shake well and pour into a rocks glass filled with ice. Garnish with a lemon strip.

IMPORTED BY BARTON IMPORTS
CHICAGO, IL • Contains: F.D.&C. YELLOW # 5



0 80660 77605 7

GOVERNMENT WARNING: (1) ACCORDING TO THE SURGEON GENERAL, WOMEN SHOULD NOT DRINK ALCOHOLIC BEVERAGES DURING PREGNANCY BECAUSE OF THE RISK OF BIRTH DEFECTS. (2) CONSUMPTION OF ALCOHOLIC BEVERAGES MAY BE HARMFUL TO YOU AND TO YOUR CHILDREN.



CARAVELLA
limoncello originale
d'Italia imported from Italy

A system for the ecological labeling of “skin pack” package, tubs and parallelepiped products. It allows for application on the upper surface, sides and base of the product.

The compact main base in stainless steel can be equipped with a thermal transfer digital coder (can be linked to a set of scales).

The limited thickness of the Linerless material, free of silicon liner, and the “short step” advancement allow for the great capacity of the label reels and consequently significant operative duration

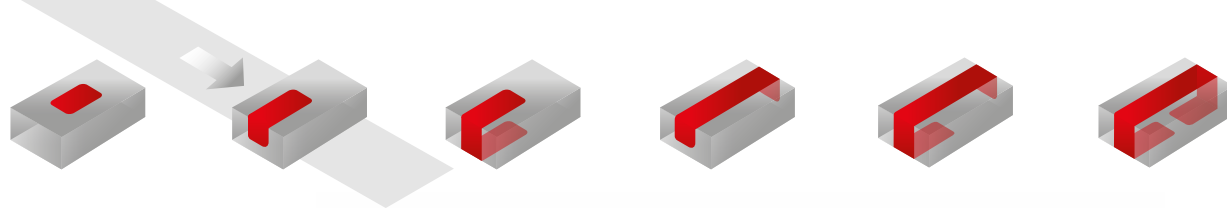

Striped Linerless

5000

Sistema per l’etichettatura ecologica di confezioni “skin pack”, vaschette e prodotti parallelepipedi.

Consente l’applicazione sulla superficie superiore, sui lati e sul fondo del prodotto.

Basamento compatto in acciaio inossidabile, equipaggiabile con codificatore digitale a trasferimento termico (collegabile a una bilancia).

Il limitato spessore del materiale Linerless, privo di supporto siliconato, e l’avanzamento a “passo corto”, consentono una grande capacità dei rotoli di etichette e di conseguenza una notevole autonomia di funzionamento

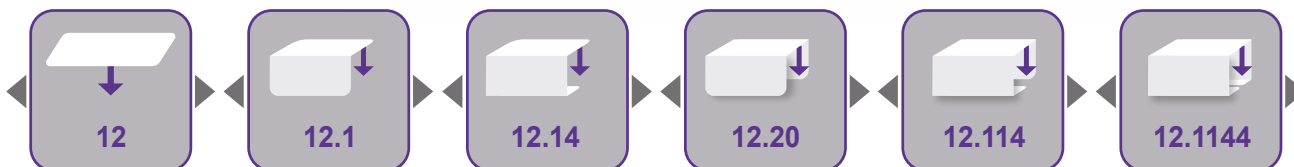



The control panel with color touchscreen display and the main adjustments are positioned ergonomically. The electric installation cabinet is easily accessible from the front side of the system

Il pannello di controllo con display touchscreen a colori e le principali regolazioni sono in posizione ergonomica. L'armadio dell'impianto elettrico è facilmente accessibile dal lato anteriore del sistema

The absence of liner and borders, the contained quantity of glue and silicon (distributed in stripes) make the Striped Linerless labels not only ecological, but also more economical than traditional self adhesive labels

L'assenza di supporto e sfridi, e la quantità contenuta di adesivo e silicone (distribuiti a strisce) rende le etichette Striped Linerless non solo ecologiche, ma anche più economiche delle tradizionali etichette autoadesive



Replacement of the reel is most rapid thanks to the very short "paper path" and no liner needing to be removed. Striped Linerless labels are of contained weight and volume; therefore they reduce warehousing costs and eliminate the need to collect and recycle the silicon liner

La sostituzione del rotolo è velocissima grazie al "giro carta" brevissimo e all'assenza del supporto da rimuovere.

Le etichette Striped Linerless hanno peso e volume contenuti; perciò riducono i costi di stoccaggio ed eliminano la necessità di raccogliere e smaltire il supporto siliconato

STRIPED LINERLESS 5000



Whether made of paper or plastic, Striped Linerless labels constitute an eye catching decorative system: economical, ecological and of maximum industrial efficiency. Available in "Slider" version to cover totally the package, hiding the product

Realizzate in carta o plastica, le etichette Striped Linerless rappresentano un'accattivante sistema di decoro: economico, ecologico e di massima efficienza industriale. Disponibili anche nella versione "Slider" per coprire completamente la confezione, nascondendo il prodotto





The Striped Linerless label can at the same time satisfy the need for primary decoration and the "weight-price" function

L'etichetta Striped Linerless può soddisfare contemporaneamente l'esigenza di decoro primario e la funzionalità "peso-prezzo"



The thermal transfer digital coder allows for printing alphanumeric characters and barcodes. It's provided with its own touch screen control unit (it doesn't require connection to PC). It can be linked to a set of scales for printing of variable weights

Il codificatore digitale a trasferimento termico consente la stampa di caratteri alfanumerici e codici a barre. E' dotato di propria unità di controllo touch screen (non richiede connessione a PC). Può essere collegato a una bilancia per la stampa del peso variabile

STRIPED LINERLESS 5000



"Ribboned" labeling also decorates the side of the product making it easily recognizable on the shelf

L'etichettatura "a fascia" decora anche il fianco del prodotto rendendolo facilmente identificabile sullo scaffale



The Striped Linerless label can also be used as a "multipack" solution to group several packages

L'etichetta Striped Linerless può essere utilizzata anche come soluzione "multipack" per raggruppare più confezioni



As it can also be made in transparent plastic material, it can be printed partially creating optical awareness of any given silhouette

Realizzabile anche in materiale plastico trasparente, può essere stampata parzialmente determinando la percezione ottica di qualsiasi sagoma rappresentata





127
Striped Linerless 5000

STRIPED LINERLESS 5000



"Ribboned" labeling also decorates the side of the product making it easily recognizable on the shelf

L'etichettatura "a fascia" decora anche il fianco del prodotto rendendolo facilmente identificabile sullo scaffale



Suitable to the new "skinpack" packaging too

Adatto anche alle nuove confezioni "skinpack"





Top labeling system (top feed) for any flexible continuous ribbon (film, labels, cardboard, etc.). The DP version is equipped with a T.T. desktop printer for basic label customization, with variable data. Another transparent protective label is thus applied at a high rate of accuracy (+/- 1mm) above each printed label. This way, labels can be produced within the production cycle, and with the utmost flexibility, that are resistant to the harshest mechanical and chemical stresses!

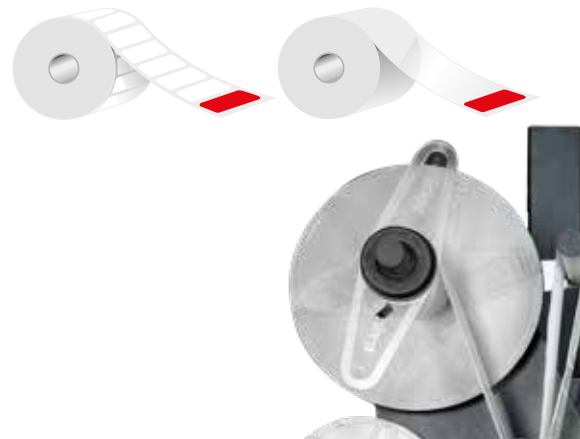

Double layer protective labels are also available, allowing for the painting of labeled products and subsequent removal of the upper protective label layer, restoring the visibility of the information printed on the underlying label

Sono disponibili anche etichette protettive a doppio strato, che consentono la verniciatura del prodotto etichettato e la successiva rimozione dello strato superiore dell'etichetta protettiva, ripristinando la visibilità delle informazioni

Converter

With the option of a printed barcode check

Possibilità di verifica dell'eventuale codice a barre stampato

Sistema per l'etichettatura Top (dall'alto) di qualsiasi banda continua flessibile (film, etichette, cartoncino, ecc.). La versione DP è dotata di stampante desktop T.T. per la personalizzazione delle etichette di base. Quindi, sopra ad ogni etichetta stampata, viene applicata con precisione (+/- 1mm) un'altra etichetta protettiva trasparente. In questo modo è possibile realizzare, all'interno del ciclo produttivo e con la massima flessibilità, etichette resistenti alle più gravose sollecitazioni meccaniche e chimiche!



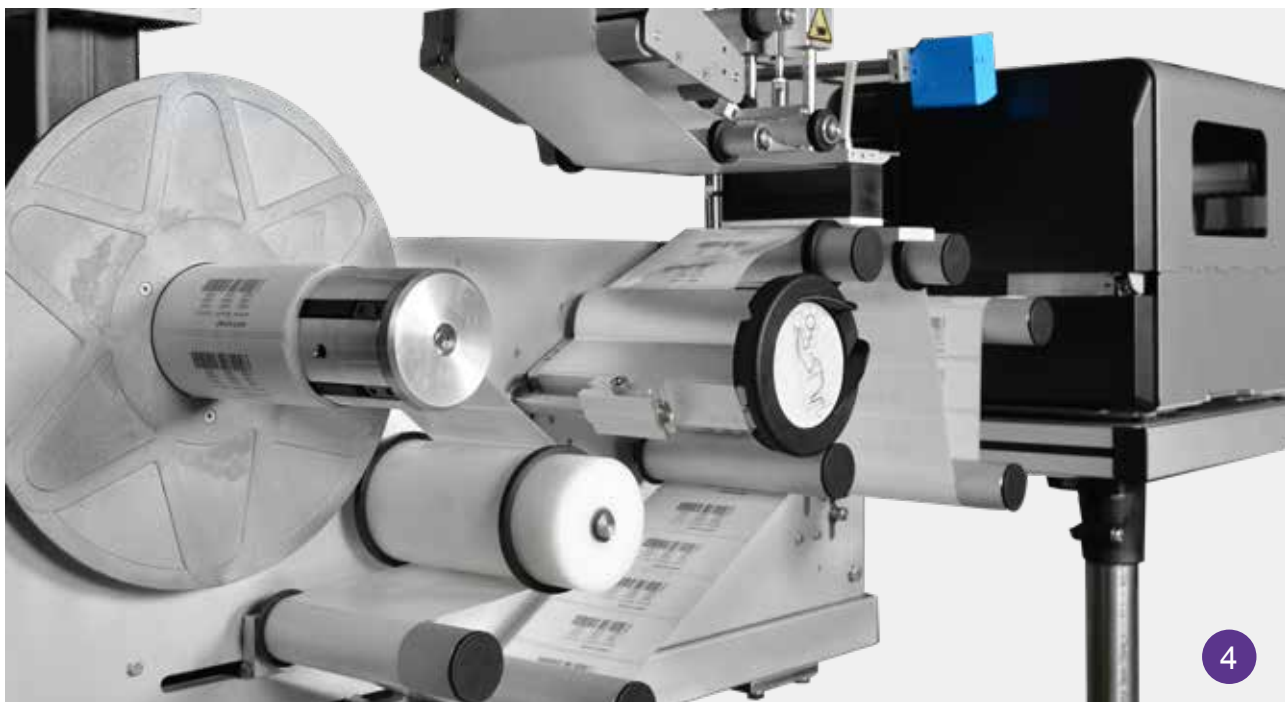

A system for labeling and/or coding flat products: laid down packets (either already glued or still “open”), telephone and credit cards, membership cards, sheets, envelopes, hang tags for clothing, etc. It allows for application on the upper surface of the product.

Its modular steel main base can be equipped with:

- a labeler (with possible thermal transfer marker), or
- a thermal inkjet print module (HP technology)
- code scanners or vision sensors, for checking printed data and actual labeling

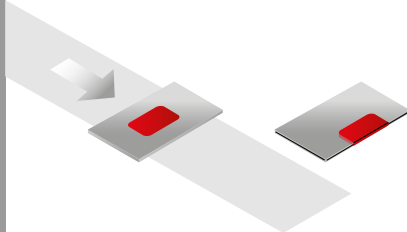

Top or C-Wrapping labeling for leaflets sealing

Etichettatura Top o C-Wrapping per la sigillatura dei pieghevoli

Feeder

Sistema per l’etichettatura e/o la codifica di prodotti piatti: astucci stesi (sia già incollati, sia ancora “aperti”), carte telefoniche e di credito, tessere, fogli, buste, pendagli per abbigliamento, ecc.

Consente l’applicazione sulla superficie superiore del prodotto.

Basamento modulare in acciaio, equipaggiabile con:

- un’etichettatrice (con eventuale marcatore a trasferimento termico), oppure
- modulo di stampa thermal inkjet (tecnologia HP)
- lettori di codici o sensori di visione, per la verifica dei dati stampati e dell’avvenuta etichettatura



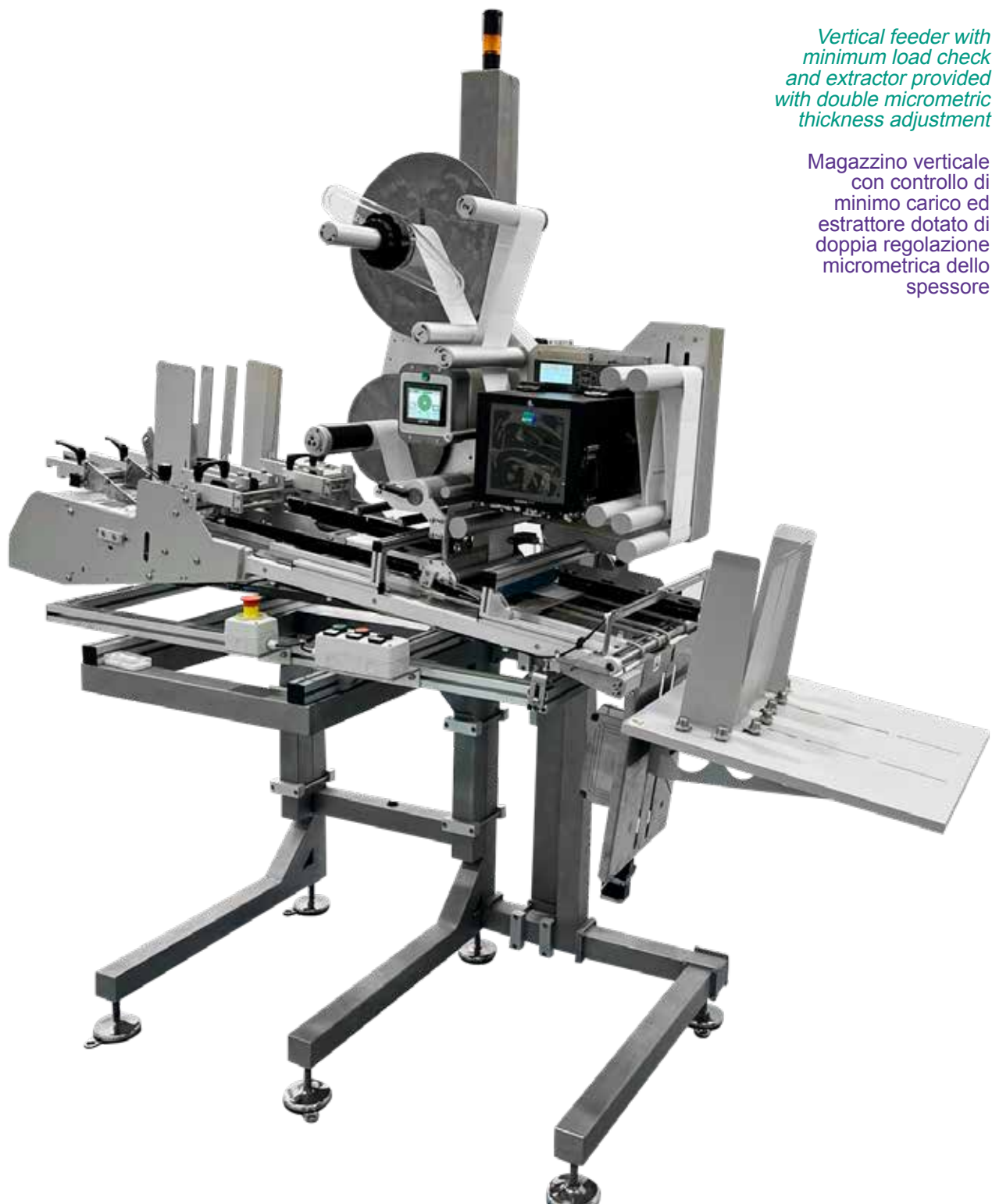

Vertical feeder with minimum load check and extractor provided with double micrometric thickness adjustment

Magazzino verticale con controllo di minimo carico ed estrattore dotato di doppia regolazione micrometrica dello spessore



Thermal inkjet marker for direct printing on leaflets

Marcatore a getto d'inchiostro termico per stampa diretta sui pieghevoli



A system for labeling, coding and tracing flat products: laid down case box (either already glued or still "open"), telephone and credit cards, membership cards, envelopes, hang tags for clothing, etc. It allows for application on the upper surface of the product.

Its modular main base in AISI 304 stainless steel can be equipped with:

- an ink jet print module of the thermal type (HP technology); up to 4 print heads*
- labeler*
- laser marker*
- code scanners, sensors or vision systems with cameras, for checking printed data and actual labeling*

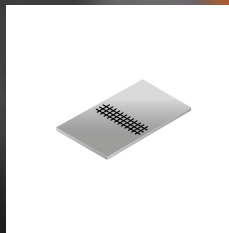

Card Board

Sistema per l'etichettatura, la codifica e la tracciabilità di prodotti piatti: astucci stesi (sia già incollati, sia ancora "aperti"), carte telefoniche e di credito, tessere, buste, pendagli per abbigliamento, ecc. Consente l'applicazione sulla superficie superiore del prodotto.

Basamento modulare in acciaio inossidabile AISI 304, equipaggiabile con:

- modulo di stampa a getto di inchiostro di tipo termico (tecnologia HP); fino a 4 testine di stampa
- etichettatrice
- marcatore laser
- lettori di codici, sensori o sistemi di visione con telecamere, per la verifica dei dati stampati e dell'avvenuta etichettatura

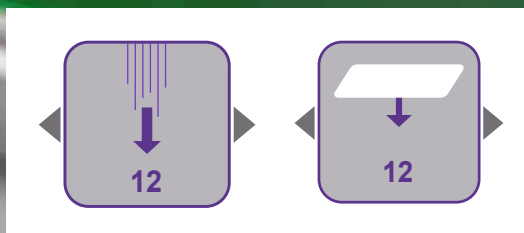
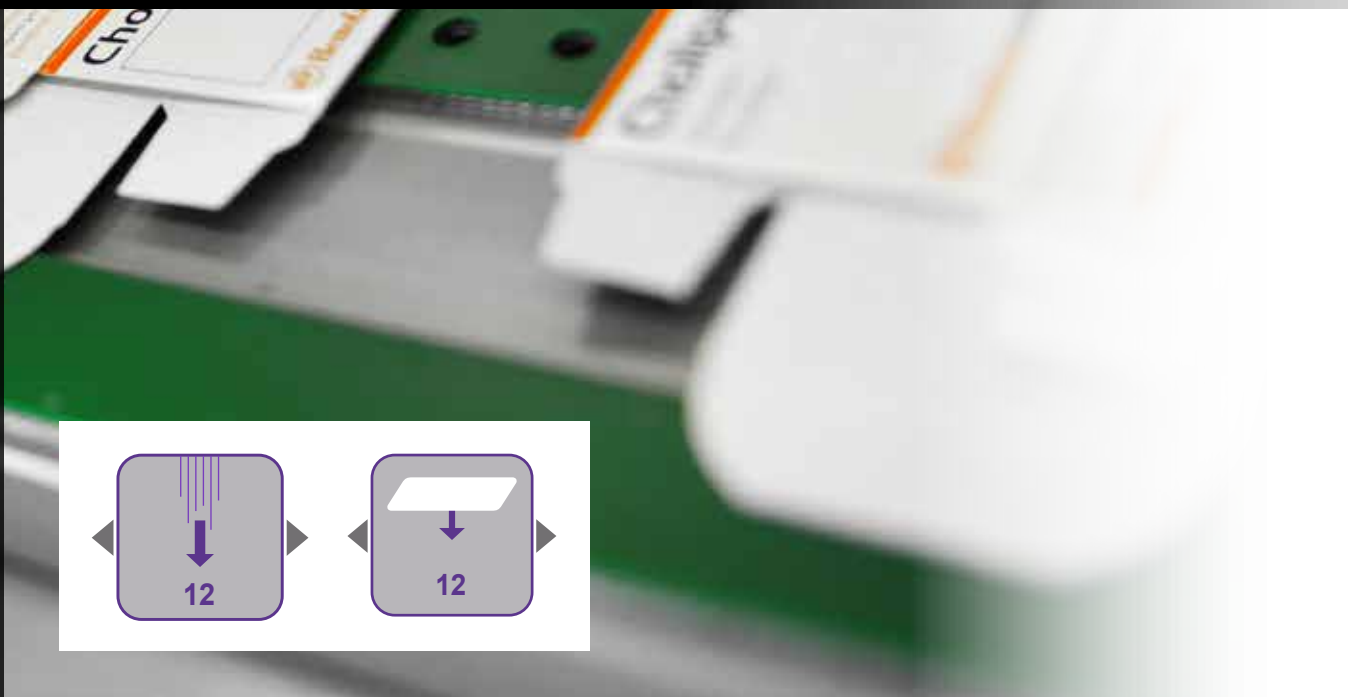



"Vacuum" transport system to guarantee positioning precision and format change flexibility. Complete with "actual product spacing" check

Sistema di trasporto "vacuum" per garantire precisione di posizionamento e flessibilità nel cambio formato. Completo di controllo "distanziamento prodotti"



Vertical feeder with minimum load check and extractor provided with micrometric thickness adjustment

Magazzino verticale con controllo di minimo carico ed estrattore dotato di regolazione micrometrica dello spessore

“Actual product spacing” check. Readability check of code and text printed on the product and on the label. Check for “actual labeling” and “actual rejection” of non conforming products

Controllo “effettivo distanziamento prodotti”. Verifica di leggibilità di codice e testo stampati sul prodotto e sull’etichetta. Controllo “avvenuta etichettatura” ed “effettivo scarto” dei prodotti non conformi



Adjustments with millimetric scale and returning handles

Regolazioni con scala millimetrata e maniglie a ripresa

In the case of incorrect or illegible coding, the label is not applied, facilitating reconciliation and allowing for identification of the rejection cause

In caso di codifica errata o illeggibile, l’etichetta non viene applicata, facilitando la riconciliazione e consentendo l’identificazione della causale di scarto

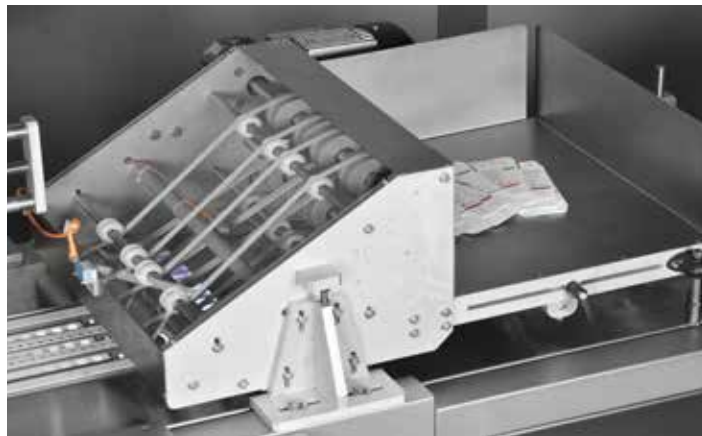

High speed mechanical switch ejector with collection bin. It sets aside non labeled products or those with the code either unreadable or not conforming with the set product

Espulsore meccanico ad alta velocità con contenitore di raccolta. Apparta i prodotti non etichettati o con codice non leggibile o non conforme al prodotto impostato

All the checks are carried out in “positive logic”, according to GAMP criteria and satisfy the maximum safety requirements. Possibility for IQ & OQ validation

Tutti i controlli sono effettuati in “logica positiva”, secondo i criteri GAMP e soddisfacendo le esigenze di massima sicurezza. Possibilità di validazione IQ, OQ

At the end of the line the products are accumulated in an orderly “fish scale” fashion; then either removed by hand, accumulated by gravity or conveyed onto the downstream line

A fine linea i prodotti sono accumulati ordinatamente “a lisca di pesce”; scaricati manualmente, raccolti per caduta o convogliati sulla linea a valle



Direct marking of the case box by laser: maximum reliability; high resolution; indelible; ecology; minimal maintenance; does not require any consumables

Marcatura diretta dell'astuccio mediante laser: massima affidabilità; alta risoluzione; indelebilità; ecologia; minima manutenzione; non richiede alcun materiale di consumo



Thermal ink jet print modules (HP technology) for printing text and barcodes (also 2D) on the case box. Up to 4 heads for a wider printing surface. A single adjustment also allows the positioning of any vision system for printing verification

Moduli di stampa a getto di inchiostro termico (tecnologia HP) per la stampa sull'astuccio di testi e codici a barre (anche 2D). Fino a 4 testine per una più ampia superficie di stampa. Un'unica regolazione consente il posizionamento anche dell'eventuale sistema di visione per la verifica della stampa



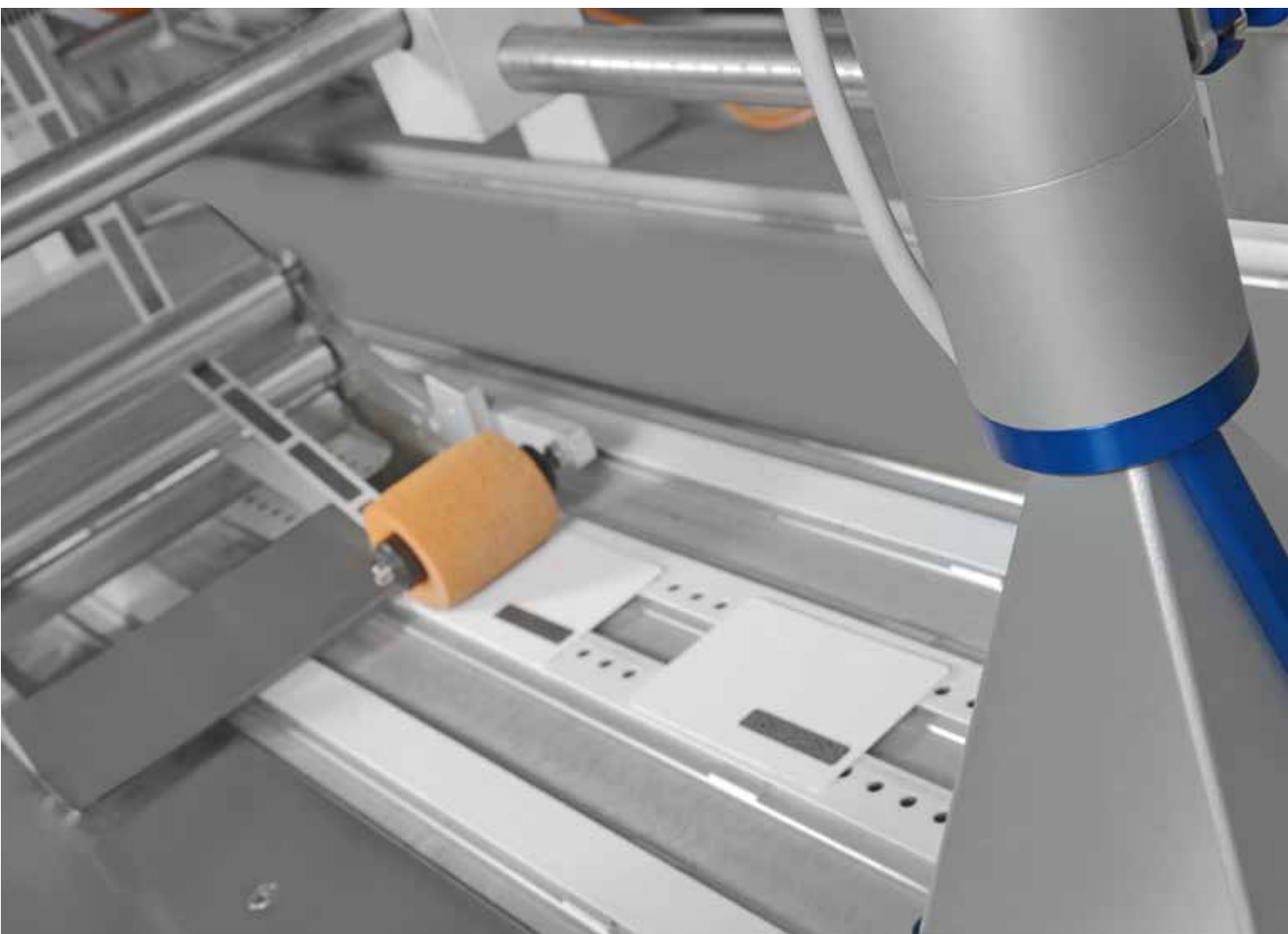

The Card Board system is ideal for application of labels on telephone and credit cards. It can be equipped with vision systems and cameras, validation and traceability software, special collection systems and labelers specifically engineered for "scratch-off" labels

Il sistema Card Board è ideale per l'applicazione di etichette sulle carte telefoniche e di credito. E' equipaggiabile con sistemi di visione e telecamere, software per la validazione e la tracciabilità, appositi sistemi di raccolta ed etichettatrici specificamente progettate per le etichette "scratch-off"



*A system for pharmaceutical case boxes sealing.
It allows the tamperproof labeling and the optical
verification of all the process phases.
Compact main base "balcony design" made in AISI
304 stainless steel, with stratified glass protection*

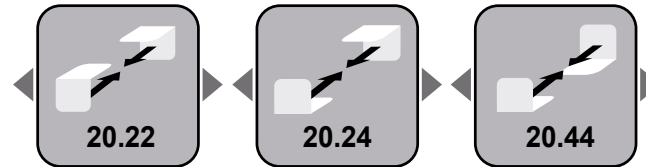
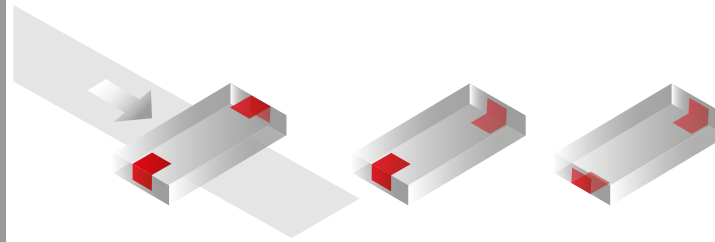

Pharma Seal 4.0

Sistema per la sigillatura di astucci farmaceutici
formati. Consente l'etichettatura antiviole e il
controllo ottico di tutte le fasi del processo.
Basamento compatto "struttura a balcone" realizzato
in acciaio inossidabile AISI 304, con protezione in
vetro stratificato





Man Machin interface monitor in ergonomic position accessible also when guard door is opened. The machine is controlled via graphic touchscreen interface with advanced 4.0 functions (CFR 21 part 11 compliant) and biometric access check; password management Microsoft Active Directory compatible

Monitor di interfaccia macchina in posizione ergonomica accessibile anche a protezione aperta. La macchina è controllata tramite interfaccia grafica touchscreen con funzioni avanzate 4.0 (conforme CFR 21 part 11) e controllo biometrico degli accessi; gestione password compatibile con Microsoft Active Directory

Indexed transport conveyor, by indexed inserter and two parallel toothed belts, for correct case box position during all the process and to avoid any slippage and product accumulation. It guarantees the best marking and labeling quality

Sistema di trasporto positivo, mediante inseritore in fase e convogliatore a due nastri paralleli dotati di spingitori, per garantire la corretta posizione dell'astuccio durante tutto il processo e impedire slittamento e accumuli di prodotto. Garantisce la migliore qualità di marcatura e etichettatura

Validatable ejector with collection bin totally transparent. It sets aside non labeled products or those with the code either unreadable or not conforming with the set product

Espulsore validabile con contenitore di raccolta completamente trasparente. Apparta i prodotti non etichettati o con codice non leggibile o non conforme al prodotto impostato



20.X

PHARMA SEAL 4.0

The compact labeling system, perfect for applying two seals, above or below the case box. It allows operation on "one side only" of the line. Quick format change thanks to electronic functions and the particular "centralized" mechanical adjustment system

Il sistema di etichettatura compatto, perfetto per l'applicazione di due sigilli, sopra o sotto l'astuccio. Consente l'operatività da un solo lato della linea. Cambio formato rapido grazie alle funzioni elettroniche e al particolare sistema di regolazioni meccaniche "centralizzate"



50,40"

1280 mm



*Vision system monitor accessible also when guard door is opened.
The machine is controlled via graphic touchscreen interface with advanced 4.0 functions (CFR 21 part 11 compliant) and biometric access check; password management
Microsoft Active Directory compatible*

Monitor del sistema di visione accessibile anche a protezione aperta.
La macchina è controllata tramite interfaccia grafica touchscreen con funzioni avanzate 4.0 (conforme CFR 21 part 11) e controllo biometrico degli accessi; gestione password compatibile con Microsoft Active Directory

Indexed transport conveyor, by indexed inserter and two parallel toothed belts, for correct case box position during all the process and to avoid any slippage and product accumulation. It guarantees the best marking and labeling quality

Sistema di trasporto positivo, mediante inseritore in fase e convogliatore a due nastri paralleli dotati di spingitori, per garantire la corretta posizione dell'astuccio durante tutto il processo e impedire slittamento e accumuli di prodotto. Garantisce la migliore qualità di marcatura e etichettatura

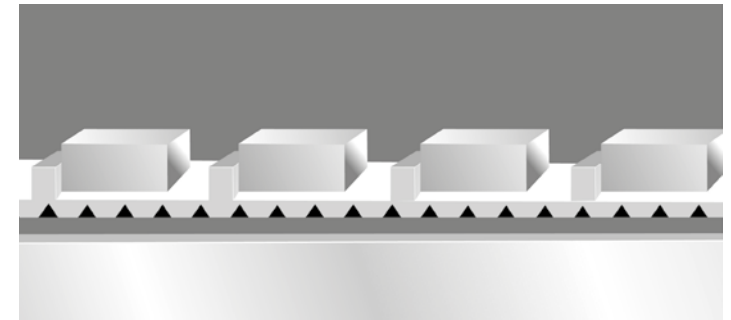

All the checks are carried out in "positive logic", according to GAMP criteria and satisfy the maximum safety requirements. Airblast product ejector with "actually rejected" check. IQ & OQ validation

Tutti i controlli sono effettuati in "logica positiva", secondo i criteri GAMP e soddisfano le esigenze di massima sicurezza. Espulsore prodotti a soffio d'aria con controllo di avvenuta espulsione. Validazione IQ, OQ

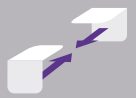

20.X

PHARMA SEAL 4.0



Indexed inserter for case box positioning on the positive toothed transport

Inseritore a passo per il posizionamento dell'astuccio su trasporto positivo dotato di spingitori

Quick format change. A main adjustment controls, with only one movement, the conveyor width and the positioning of the inserter, labelers and seal adapters. "Fine tuning" adjustment (for special configurations) all positioned on the operator side, with numerical position indicators and security fastening

Cambio formato rapido. Una regolazione principale controlla, con un solo movimento, la larghezza del convogliatore e il posizionamento dell'inseritore, etichettatrici e adattatori sigilli. Regolazioni per "fine tuning" (per configurazioni particolari) tutte posizionate sul lato operatore e con indicatori numerici di posizione e fissaggio di sicurezza



Validatable ejector with collection bin totally transparent. It sets aside non labeled products or those with the code either unreadable or not conforming with the set product

Espulsore validabile con contenitore di raccolta completamente trasparente. Apparta i prodotti non etichettati o con codice non leggibile o non conforme al prodotto impostato



Vignette labeler (optional) with online printing devices too

Etichettatrice per bollino farmaceutico (opzionale) anche con dispositivi di stampa online



Roll housing in ergonomic position with extremely low "siliconized backing path"

Alloggiamento rotoli in posizione ergonomica con "percorso supporto siliconato" estremamente contenuto

The pictures shown in this publication are purely indicative

The illustrated devices can be supplied, serial or as optionals, for all or only for a part of the labelers. To check the specific equipment of each model, please refer to the specific offer/order confirmation issued by Arca

Arca reserve the right to make, without prior warning, changes to the series equipment and machine construction modifications which may bring about variations to the features and performance indicated here. To check the validity of the information contained in this publication, please consult the prevailing Arca pricelist

This publication shows products labeled by Arca machines or with their labels. Any reproduction of third party products, identified by their respective brand, takes place solely and uniquely with the aim of showing the technical features of our products or of the application

AIR ASSIST, AIR JET, ARCA CLIP, EASY, EASY JET, DYNAMIC, DOWN UNDER, DUAL BRIDGE, DUAL SPRING, EASYLINER, EVOLUTION, FLASH, HPS - HIGH PRECISION SAFE, HIGH PRECISION SLIM, HIGH SPEED, INSPECTOR, LINERLESS, LINERPLUS, L-SEAL, MAGIC DOOR, MICRO, MINI EASY JET, NON STOP, POWERKIT, QUICK CHANGE, QUICK OPENING, U-SEAL, PIVOT-R BOX, PIVOT-R PALLET, REVERSE, SCANMANAGER, SOFT L-SEAL, SINGLE BRIDGE, WIND

The above names are virtual trademarks objectively attributable to the property of Arca Etichette on a documental basis. The use or reproduction by any means of the above mentioned trademarks by third parties is explicitly forbidden

Delrin, Sato, Zebra, Dataflex, Wolke are third parties' trademarks

Disclaimer



www.arcalabelingmarking.com

Le immagini rappresentate in questa pubblicazione sono da considerarsi puramente indicative

I dispositivi illustrati possono essere forniti, di serie o come opzionali, per tutte o solo per parte delle etichettatrici. Per verificare la specifica dotazione di ciascun modello fare riferimento alla specifica offerta/conferma d'ordine emessa da Arca

Arca si riserva la facoltà di apportare, senza preavviso, cambiamenti della dotazione di serie e modifiche costruttive alle macchine che possano comportare variazioni delle caratteristiche e delle prestazioni qui indicate. Per verificare l'attualità delle informazioni riportate nella presente pubblicazione, è necessario consultare il listino prezzi Arca in vigore

In questa pubblicazione sono rappresentati prodotti etichettati da macchine o con etichette Arca. L'eventuale riproduzione di prodotti di terzi, identificati dal rispettivo marchio, avviene al solo ed unico scopo di mostrare le caratteristiche tecniche dei nostri prodotti o dell'applicazione

AIR ASSIST, AIR JET, ARCA CLIP, EASY, EASY JET, DYNAMIC, DOWN UNDER, DUAL BRIDGE, DUAL SPRING, EASYLINER, EVOLUTION, FLASH, HPS - HIGH PRECISION SAFE, HIGH PRECISION SLIM, HIGH SPEED, INSPECTOR, LINERLESS, LINERPLUS, L-SEAL, MAGIC DOOR, MICRO, MINI EASY JET, NON STOP, POWERKIT, QUICK CHANGE, QUICK OPENING, U-SEAL, PIVOT-R BOX, PIVOT-R PALLET, REVERSE, SCANMANAGER, SOFT L-SEAL, SINGLE BRIDGE, WIND

I nomi suddetti sono marchi di fatto oggettivamente riconducibili alla titolarità di Arca Etichette, su base documentale. E' fatto espresso divieto a terzi, di uso o riproduzione con qualsiasi mezzo

Delrin, Sato, Zebra, Dataflex, Wolke, sono marchi di terzi

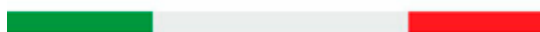

M A D E I N I T A L Y