

The Arca logo consists of the word "arca" in a white, lowercase, sans-serif font, positioned to the left of a stylized graphic element. This graphic element is composed of two overlapping rectangular shapes: a purple one on top and a teal one on the bottom, both pointing towards the right.

arca

The background of the slide is a collage of industrial and technical imagery. In the upper right, a blue laser marker is shown emitting several bright, parallel laser beams. In the lower right, a close-up of a control panel features several buttons, some with yellow warning triangles, and a power symbol. The background also includes faint technical drawings and a teal-to-purple gradient.

LASER MARKERS & LASER MARKING STATIONS

Lasers markers & laser marking stations

LASER MARKERS BENEFITS	p.4
LASER MARKERS RANGE	p.5
LASER MARKERS SOLIDITY AND SAFETY	p.6
LASER MARKERS CONTROL UNIT	p.7
LASER MARKERS CO ₂	p.8
LASER MARKERS FIBER	p.10
LASER MARKERS DPSS UV	p.12
LASER MARKERS 3 AXES CONTROL	p.14
LASER MARKERS FOR MATERIALS	p.15
LASER MARKERS FOR CONSUMER GOODS <i>FOOD & BEVERAGE</i>	p.16
LASER MARKERS FOR CONSUMER GOODS <i>PHARMA & COSMETICS</i>	p.18
LASER MARKERS FOR CONSUMER GOODS <i>DURABLE GOODS</i>	p.20
LASER MARKERS SUPPORT STRUCTURE	p.22
LASER MARKERS BOX	p.23
LASER MARKERS STATIONS	p.24

LASER FOR <i>CONTACT LENS</i>	p.27
LASER FOR <i>METAL PLATE AND TAGS</i>	p.29
LASER FOR <i>ENGINE PARTS</i>	p.31
LASER FOR <i>CARDBOARD AND PVC CORE</i>	p.33
LASER FOR <i>EXTRUSIONS AND PROFILES</i>	p.35
LASER FOR <i>AUTOMOTIVE PLASTIC PARTS</i>	p.37
LASER FOR <i>TAPS AND HYDRAULIC PARTS</i>	p.39
CUSTOMIZED SOLUTIONS	p.44
LASER FOR <i>WOODEN BARRELS</i>	p.45
LASER FOR <i>WOODEN BOARDS</i>	p.47
LASER ON LABELS	p.48
LASER FOR <i>SELF-ADHESIVE LABELS</i>	p.49
LASER FOR <i>SELF-ADHESIVE MATERIALS</i>	p.53
ACCESSORIES	p.56

SALES	p.58
PRODUCTION	p.60
RESEARCH & DEVELOPMENT	p.62
TECHNICAL ASSISTANCE	p.64
WAREHOUSE	p.66

Laser è l'acronimo di Light Amplification by Stimulated Emission of Radiation (amplificazione della luce mediante emissione stimolata di radiazioni). Una sorgente di radiazione elettromagnetica che amplifica la luce monocromatica, coerente (monodirezionale), concentrata, con elevatissima densità di potenza

La marcatura laser è una tecnologia di "stampa senza contatto" che offre una serie di vantaggi indiscutibili rispetto alle metodologie alternative

- indelebilità. La marcatura laser è per sempre!
- economia di esercizio. Il laser non impiega nessun materiale di consumo (es: nessun inchiostro liquido o nastro a trasferimento termico)
- alta qualità grafica, sempre assolutamente costante nel tempo
- produttività ineguagliata grazie alla possibilità di lavorare continuamente, senza nessun arresto per l'approvvigionamento del materiale di consumo. Il laser è un sistema di marcatura "NON STOP"!
- minima manutenzione grazie all'assenza di parti in movimento e componenti soggetti ad usura
- ecologia. Il laser non produce residui da smaltire
- pulizia assoluta. La luce non sporca!

Marcatori laser

Laser markers

The term LASER is the acronym for Light Amplification by Stimulated Emission of Radiation: a source of electromagnetic radiation that amplifies a monochromatic, coherent (unidirectional) and concentrated light source with high power density

Laser marking is a "contact free print" technology that offers a range of undeniable benefits compared to alternative processes

- *indelible: laser marking is forever!*
- *cost efficient: lasers don't require any consumables (e.g. no liquid ink or thermal transfer ribbon required)*
- *high graphic quality that is always absolutely constant over time*
- *unparalleled productivity thanks to the possibility of continuous operation, with no down time for replacing consumables: lasers provide a "NON STOP" marking system!*
- *minimum maintenance requirements, thanks to an absence of moving parts and components subject to wear*
- *eco-friendly : lasers don't produce any residual waste*
- *absolutely clean: light is clean!*

Il laser è il sistema di marcatura e codifica più moderno, efficiente, efficace. Un investimento con un ritorno certo e facilmente quantificabile

Arca offre una gamma completa di marcatori e stazioni di marcatura, accessori, protezioni, aspiratori che consentono lo sfruttamento ottimale della tecnologia laser

La gamma Arca di marcatori laser industriali include tutte le tecnologie più attuali e innovative: CO₂, Fiber (Q-switched e MOPA), DPSS UV; ciascuna idonea ad ottenere il miglior risultato in funzione del materiale da marcare

Una serie completa di modelli, di varie potenze, per ogni esigenza produttiva

Control unit



CO₂



Fiber Q-switched
Fiber MOPA



DPSS UV



Lasers provide the most advanced marking and encoding system, a process that is both efficient and effective. An investment with a certain return that is easily quantifiable

Arca offers a complete range of markers and marking stations, accessories, protection and suction systems that allow laser technology to be fully exploited

The Arca range of industrial laser markers includes all the most advanced and innovative technologies: CO₂ and Fiber (Q-switched and MOPA), DPSS UV; each suitable for providing the best results depending on the material to be marked

A complete range of models, of various power specifications, for every production need

I marcatori laser Arca si distinguono per solidità industriale e sicurezza

Realizzati in acciaio inossidabile e disponibili in versione IP65, sono robustissimi ed impiegano componentistica di alto livello. Nessuna improvvisazione: le migliori sorgenti laser e lenti focali disponibili sul mercato mondiale, per offrire prestazioni ed un'aspettativa di vita ai vertici della tecnologia internazionale

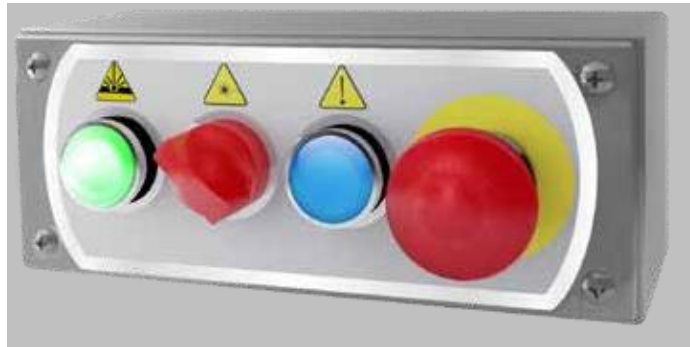

Arca laser markers feature solid industrial construction and safe operation

Built in stainless steel and available in the IP65 version, these laser markers are very robust and make use high level components. No improvisation: the best laser sources and focal lenses available anywhere in the world, offering top performance and life expectancy for leading global technology

Abilitazione macchina controllata da selettore a chiave

Circuito del pulsante di emergenza completo di interruzione e circuito di controllo protezioni con sistema di blocco (interlock). Entrambi i circuiti sono dotati di proprio modulo di sicurezza (Pilz-Pnoz) a doppio canale ridondante, con ripristino obbligatorio. I moduli sono certificati fino al performance level "PL-e" secondo EN ISO 13849-1 e SIL CL 3 secondo EN/IEC62061. Un unico connettore industriale (I/O) multifunzione, permette la gestione ottimale di tutti gli stati macchina e della condizione di allarme



Key switch controlled machine enabling

Emergency button circuit including interruption device and safety guards circuit with blocking system (interlock). Both circuits come with its own safety module (Pilz-Pnoz) with double redundant channel, with compulsory reset. The models are certified until "PL-e" performance level by EN ISO 13849-1 and SIL CL 3 by EN/IEC62061

A single industrial multifunction connector (I/O) allows for optimal management of all machine states and alarm conditions



Made in **ITALY**

L'unità di controllo con interruttore generale e LED di stato in posizione ergonomica, può essere fissata su colonna o collocata in posizione orizzontale (desktop) o verticale (tower), grazie alla predisposizione dei supporti, per la più agevole integrazione con la linea produttiva

The ergonomically positioned control unit with a main switch and status LEDs can be assembled to an upright or set in a horizontal position (desktop) or vertical position (tower), thanks to the arrangement of the supports, for easier integration with the production line

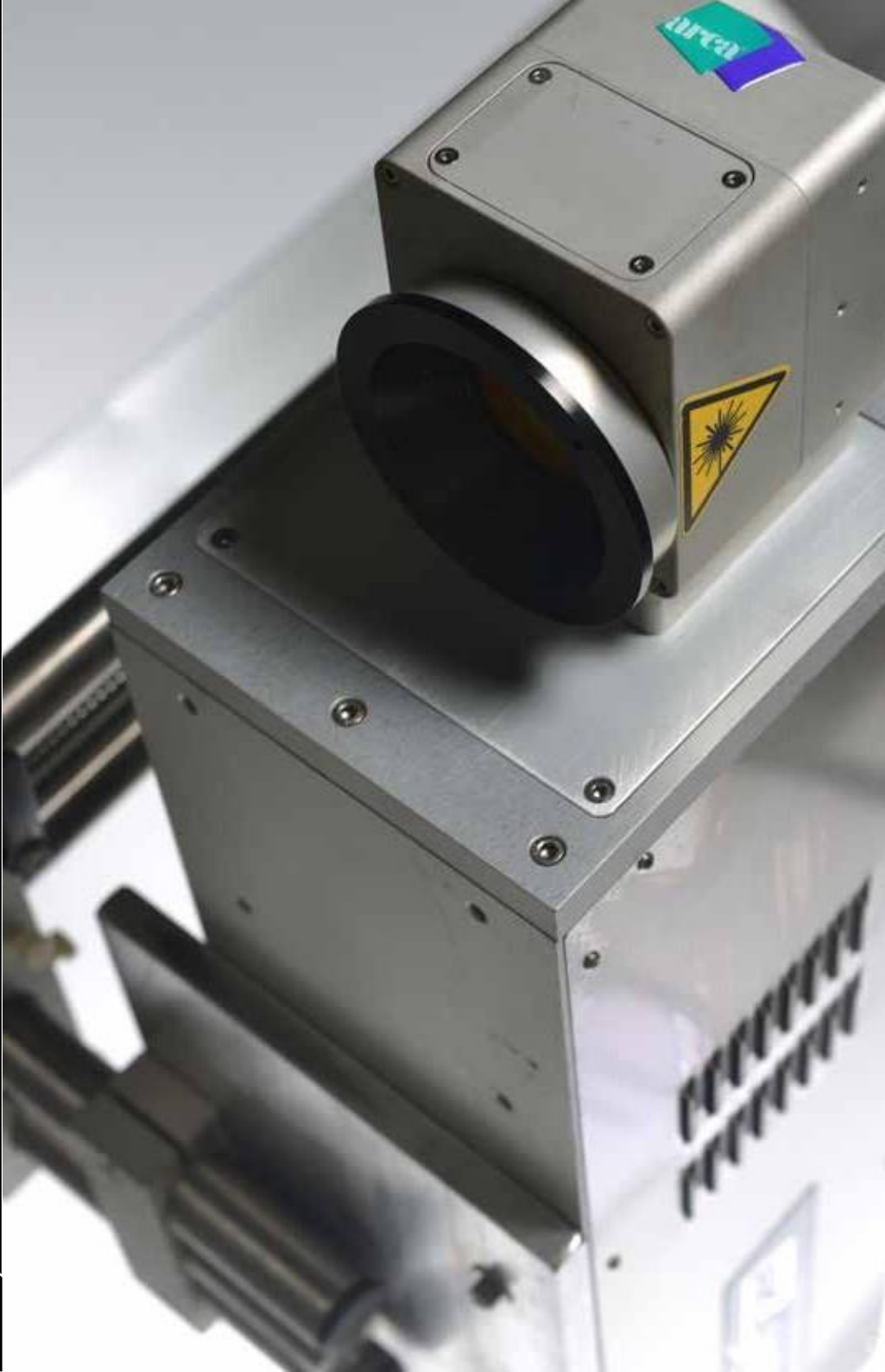

Il laser CO₂ (sorgente sigillata allo stato gassoso) è una soluzione con una aspettativa di vita di 40.000 ore, adatta alla marcatura su materiali organici, polimeri, resine e materiali vetrosi e ceramici

Utilizzato anche per la marcatura su etichette realizzate con materiali speciali o trattati con apposite vernici fotosensibili

CO₂ lasers (sealed light source in a gaseous state) is a solution with expected lifetime of 40.000 hours, suitable for marking on organic materials, polymers, resin, glass and ceramics

Also usable for marking on labels designed with special materials or treated with special photosensitive paints



Il laser a fibra (sorgente laser a luce pulsata, trasmessa mediante fibra ottica) è adatto alla marcatura sulla grande maggioranza delle superfici, inclusi metalli, polimeri e materiali ceramici. Consente una migliore definizione della stampa ed una superiore aspettativa di vita (100.000 ore) Grazie alle dimensioni compatte, il marcatore è facilmente inseribile su qualsiasi etichettatrice per la marcatura di dati variabili su etichette.

Laser Fiber di tipo Q-switched

Produce un fascio di luce "impulsato". Questa tecnica permette una potenza di picco estremamente alta, ideale per marcare anche sui materiali più resistenti.



Fiber lasers (laser pulsed light, transmitted through fiber optics) are suitable for marking on the majority of surface materials, including metals, polymers and ceramics. Allow for better print definition and a higher life expectancy (100.000 hours). Thanks to its compact size, the marker can be placed on any kind of labeler for marking variable data on labels

Q-Switched type Fiber laser

Produces a "pulsed" beam of light. This technique allows extremely high peak power, ideal for marking on even the most resistant materials.

Laser Fiber di tipo MOPA (Master Oscillator Power Amplifier)

Consente di marcare materie plastiche con risultati più nitidi, leggibili e con un maggiore contrasto. E' possibile realizzare marcature in modo più rapido di quanto non sia possibile fare con il tipo Q-switched. Inoltre è possibile eseguire la marcatura in nero di alluminio anodizzato o riprodurre colori su acciaio inox.

MOPA type Fiber laser (Master Oscillator Power Amplifier)

Allows to mark plastics with sharper, legible results and with greater contrast. Markings can be made faster than with the Q-switch type. It is also possible to mark in black anodized aluminum or reproduce colors on stainless steel.

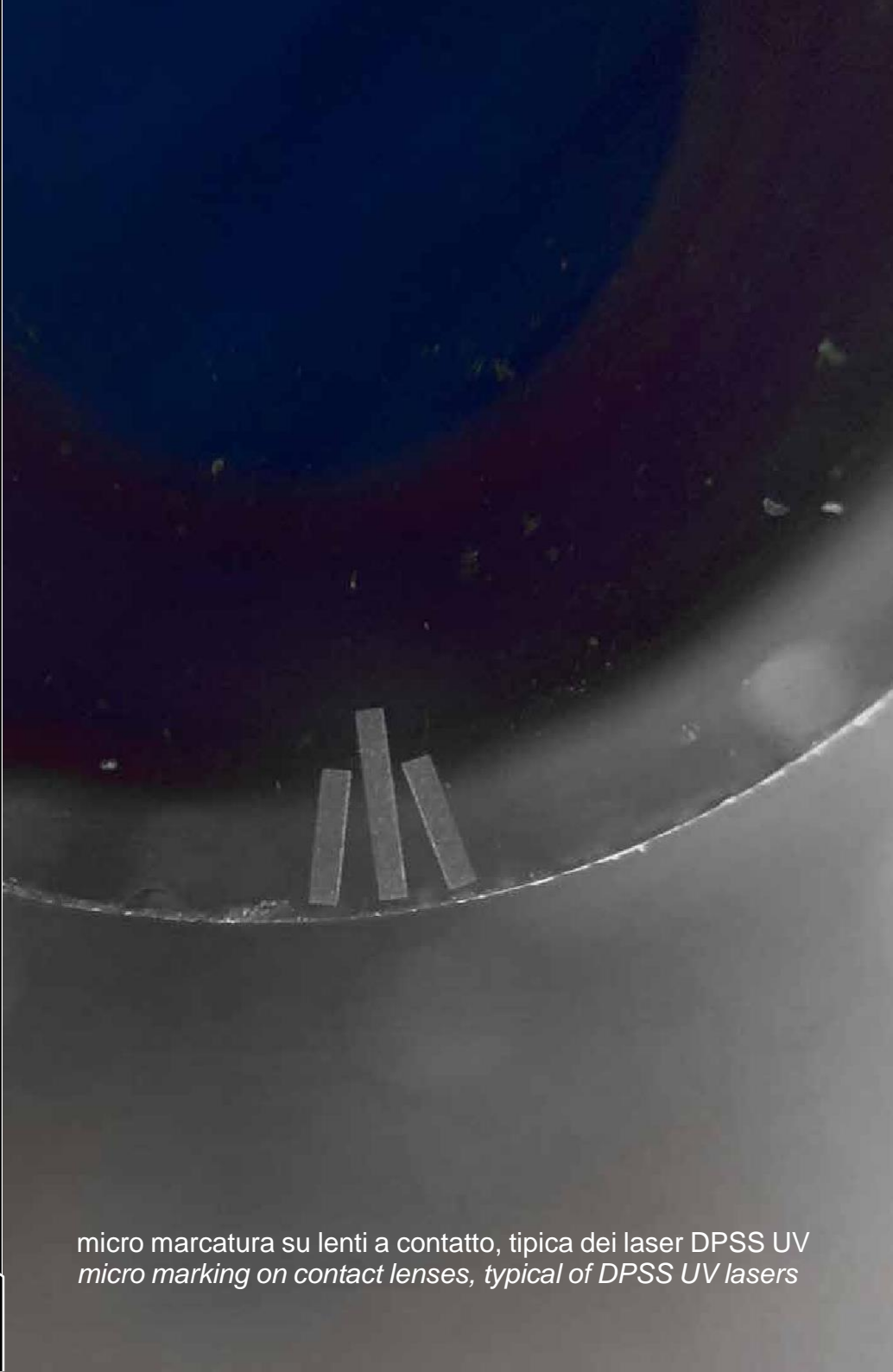

A microscopic view of three contact lenses arranged in a row on a dark, curved surface. The lenses are light-colored and show distinct, sharp laser markings on their surfaces. The background is dark and slightly out of focus, emphasizing the precision of the laser marking process.

micro marcatura su lenti a contatto, tipica dei laser DPSS UV
micro marking on contact lenses, typical of DPSS UV lasers

Il laser DPSS (Diode Pumped Solid State UV) rappresenta la soluzione di più alto livello qualitativo, nel mondo della marcatura. Lavora su lunghezze d'onda corte che garantiscono un migliore risultato in termini di assorbimento su tutti i materiali. Non innalza la temperatura della superficie marcata prevenendo la formazione di bave, colorazioni indesiderate, deformazioni strutturali e richiedendo una limitata quantità di potenza. Nessun danno al prodotto e alto contrasto di marcatura

The DPSS laser (Diode Pumped Solid State UV) represents the highest quality solution in the world of marking. It works on short wavelengths which offers a better result in terms of absorption on all materials. Do not raise the temperature of the marked surface by preventing the formation of burrs, unwanted coloring, deformations and requiring a limited amount of power. No damage to the product and high marking contrast

Laser DPSS di tipo UV
Lunghezza d'onda 355nm. Stress termico inesistente
(marcatore freddo). Ideale per i materiali sensibili all'alta
temperatura. La limitata dimensione dello spot consente la
massima risoluzione. Una marcatura perfetta per un risultato
di alta qualità estetica



*UV type DPSS laser
Wavelength 355nm. Thermal stress non-existent (cold
marking). Ideal for high temperature sensitive materials.
The limited size of the spot allows the maximum resolution.
A perfect marking for a result of high aesthetic quality*



Tutti i marcatori laser Arca, di qualsiasi tecnologia, possono impiegare un modulo di controllo a 3 assi della marcatura. In questo modo è possibile marcare su piani diversi, superfici inclinate e curve. Il controllo a 3 assi consente di evitare onerosi sistemi di movimentazione del pezzo o la sostituzione delle dime di supporto del pezzo stesso.

All Arca laser markers, of any technology, can be equipped with 3-axis marking control module. In this way it is possible to mark on different planes, inclined and curved surfaces. The 3-axis control makes it possible to avoid expensive workpiece handling systems or the replacement of the support templates for the workpiece itself.

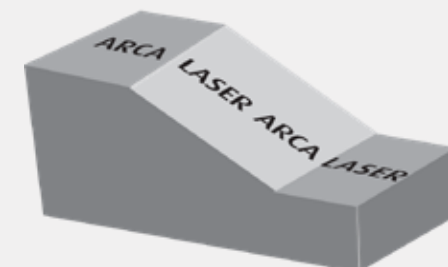

MATERIAL	CODE	CO ₂ 10,6um	CO ₂ 10,2um	CO ₂ 9,3um	FIBER Q-SWITCHED 1070nm	FIBER MOPA 1070nm	DPSS UV 355nm
Stainless steel / Acciaio inox	SUS	X	X	X	●●●	●●●	●●
Iron / Ferro	Fe	X	X	X	●●●	●●●	●●
Aluminum / Alluminio	Al	X	X	X	●●●	●●●	●●
Nickel / Nichel	Ni	X	X	X	●●	●●	●●●
Copper / Rame	Cu	X	X	X	●●	●●	●●●
Gold / Oro	Au	X	X	X	●●	●●	●●●
Polyethylene / Polietilene	PE	●●	●●	●●	●	●●	●●●
Polycarbonate / Policarbonato	PC	●●	●●●	●●●	●●	●●	●●●
Polypropylene / Polipropilene	PP	●	●	●	●●	●●●	●●●
Polyacetal / Poliacetale	POM	●●	●●	●●	●●	●●	●●●
Polibutilentereftalato Polibutilene tereftalato	PBT	●	●	●	●●	●●●	●●●
Polybutylene terephthalate / Polibutilentereftalato	PET	●●	●●	●●●	X	X	●●●
Acrylonitrile butadiene styrene / Stirene Acrilonitrile-Butadiene	ABS	●	●	●	●●	●●●	●●●
Polyurethane / Poliuretano	PTU	●●●	●●●	●●●	●●	●●	●●●
Polyvinylchloride / Cloruro di Polivinile	PVC	●●●	●●●	●●●	●●	●●	●●●
Polyamide / Poliammide	PA	●●	●●	●●	●●	●●	●●●
Repoxy resin / Resina Epossidica	EP	●	●	●	●●	●●●	●●●
Polifenilensulfide / Polifenilensulfide	PPS	●●	●●	●●	●	●●	●●●
Polystyrene / Polistirolo	PS	●●	●●	●●	●●	●●●	●●●
Polyamide / Poliammide	PI	●	●	●	●	●	●●●
Fiberglass / Lana di Vetro	VTR	●●	●●	●●	●●	●●	●●●
Phenolic resin / Resina Fenolica	PF	●	●	●	●●	●●●	●●●
Silicon / Silicone	SI	●	●	●	●	●	●●●
Pottery / Ceramica	-	●	●	●	●●	●●	●●●
Wood / Legno	-	●●●	●●●	●●●	●	●	●
Paper / Carta	-	●●●	●●●	●●●	●	●	●
Glass / Vetro	-	●●●	●●●	●●●	X	X	●●
Rubber / Gomma	-	●●	●●	●●	●●	●●	●●

Informazioni indicative. Per identificare la soluzione ideale per la marcatura di ciascun prodotto, sono richiesti specifici test

Indicative information. To identify the ideal solution for the marking of each product, specific tests are required

food&beverage



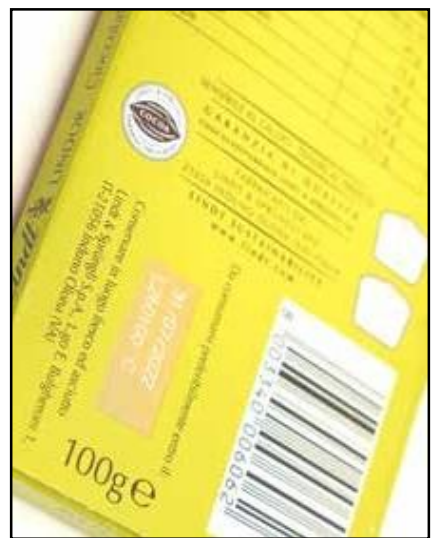

food&beverage

pharma&cosmetic





pharma&cosmetic

Durable goods



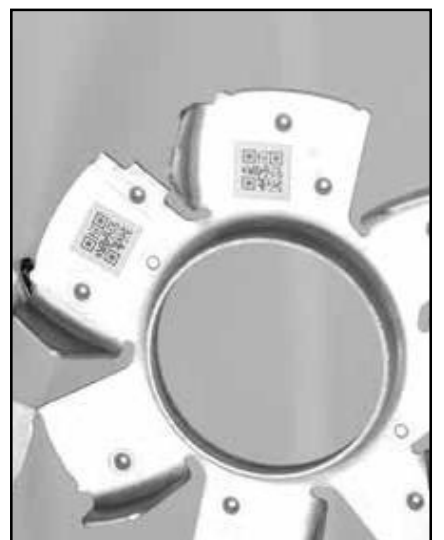

Durable goods

Struttura di sostegno da banco per marcatore laser, con regolazione di posizione sopra al prodotto da marcare, per la messa a fuoco ottimale.
Soluzione "entry level" in classe 4

Completo di regolazione verticale con vite a ricircolo di sfere e regolazione orizzontale (entrambe con riferimenti millimetrati). Il piano di appoggio è preforato per l'agevole posizione di eventuali dime

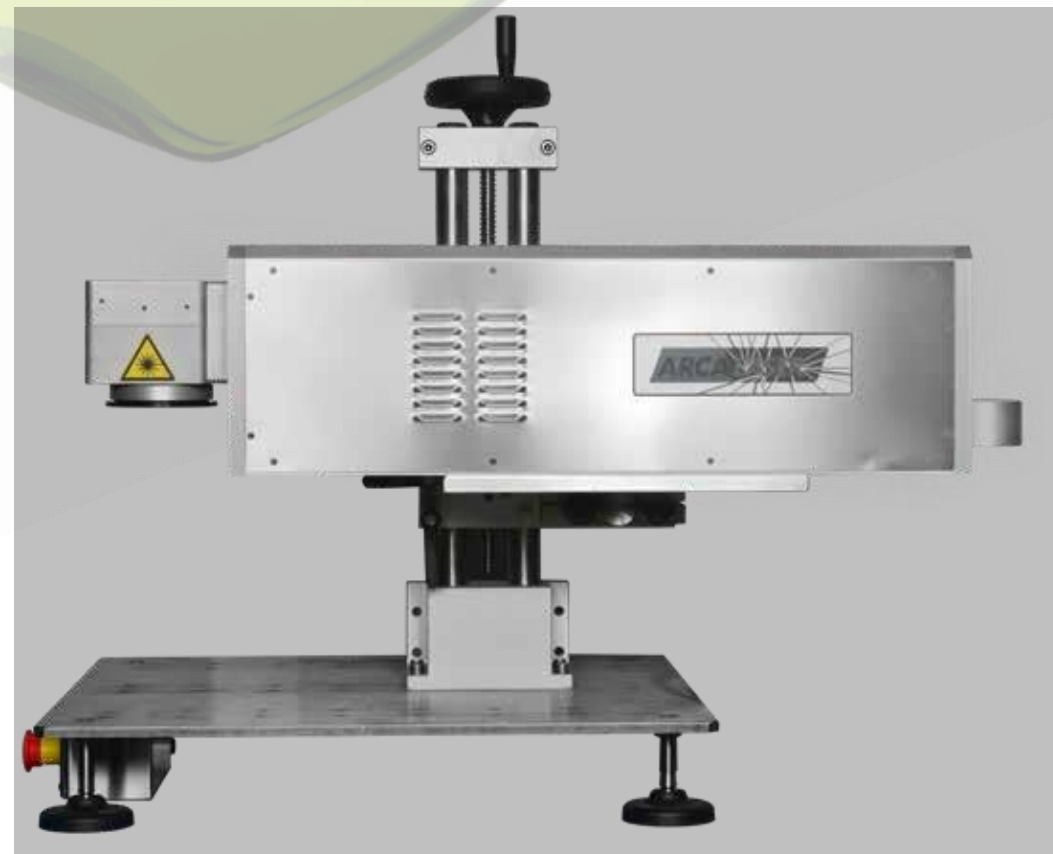

*Counter support structure for laser marker. Adjust the positioning above the product to be marked allowing for optimum focus.
Class 4 "entry level" solution*

Complete with a vertical recirculating ball screw adjustment and horizontal adjustment (both with millimetric references). The base is perforated for the easy positioning of possible templates

Protezione antinfortunistica Laser Box per marcatore laser.
Soluzione "entry level" in classe 1



*Laser Box accident prevention protection system for laser marker.
Class 1 "entry level" solution*

Finestra di ispezione e illuminazione interna a LED.
Regolazione verticale di posizione per marcatura da sopra, completa di volantino e riferimenti millimetrati

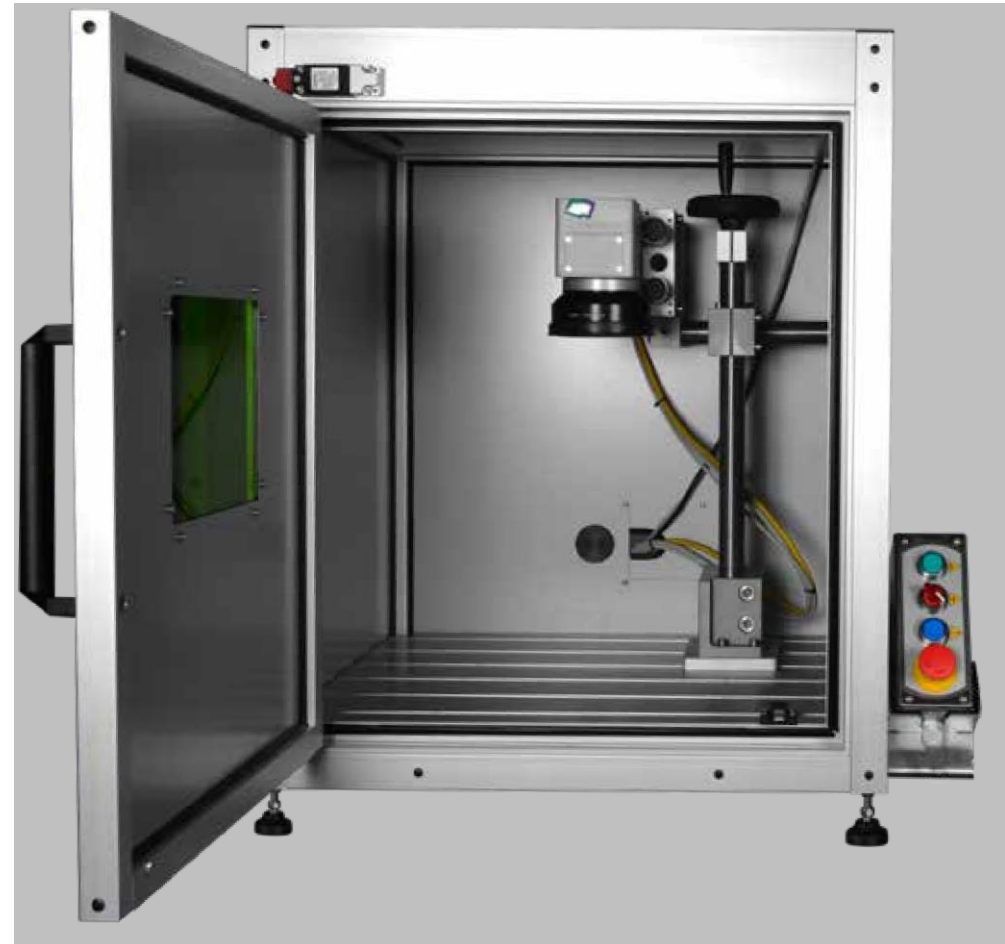

*Viewing window and internal LEDs lighting.
Vertical position adjustment for marking from above;
it comes with handwheel and millimetric references*



Stazioni di marcatura 840

Marking station 840



Stazioni di marcatura 1240

Marking station 1240

La stazione di marcatura laser è robustissima e concepita per ambienti industriali; realizzata in acciaio trattato a polvere epossidica antigraffio. È disponibile in versione compatta di lunghezza 840mm (lato operativo) e in versione 1240mm; quest'ultima in condizione di ospitare sistemi di movimentazione dei prodotti da marcare (robot) e sistemi di movimentazione del marcatore stesso. Inoltre la versione 1240 può essere dotata di tavola rotante per incremento della produttività anche in caso di caricamento manuale del pezzo singolo.

La sagoma della stazione e il posizionamento delle pulsantiere di comando, consentono l'ottimale avvicinamento per la migliore operatività. I pannelli laterali possono essere apribili manualmente, per facilitare la manutenzione e la regolazione di posizione del marcatore (quando manuale). Oppure, dotati di accessi per il transito dei prodotti su convogliatore. L'apertura principale e la regolazione di posizione del marcatore laser possono essere entrambe manuali o automatiche. La stazione di marcatura può essere dotata di contenitore di raccolta dei prodotti non conformi

The laser marking station is very robust and designed for industrial environments; made of scratch-resistant epoxy powder treated steel. It is available in a compact version, length 840mm (operating side) and in a 1240mm version; the last one can house movement systems for the products to be marked (robots) and marker movement systems. In addition, the 1240 version can be equipped with a rotary table to increase productivity even in the case of manual loading of the single piece.

The shape of the station and the positioning of the control push-buttons allow the optimal approach for the best operation.

The side panels can be opened manually, to facilitate maintenance and position adjustment of the marker (when manual). Or, equipped with accesses for the transit of the products on the conveyor. The main opening and the position adjustment of the laser marker can be both manual or automatic.

The marking station can be equipped with a collection container for non-compliant products



Sistema per la micromarcatura di lenti a contatto. Integra un sistema di visione ad alta risoluzione in condizione di rilevare il profilo della lente e un dispositivo di posizionamento automatico (precisione complessiva di 0,01 mm)

- integrazione 4.0 con il sistema informativo del cliente
- infinite possibilità di personalizzazione del dato anche ai fini della tracciabilità
- sistema di caricamento facilitato con avvicinamento del pezzo all'operatore

Contact lens micro-marking system. It integrates a high resolution vision system capable of detecting the lens profile and an automatic positioning device (overall accuracy 0.01 mm)

- 4.0 integration with the customer's information system
- endless possibilities of personalization of the data also for traceability purposes
- easy loading system with the piece approaching the operator





1 marcatore fiber laser
3 magazzini di carico e scarico
per lavorazione contemporanea di targhette
di formato diverso.
Apertura automatica frontale e apertura
laterale per accesso agevole in caso di
manutenzione.
Robot per la movimentazione rapida e
precisa dei pezzi da marcare

1 fiber laser marker
3 loading and unloading warehouses
for simultaneous processing of tags of
different sizes.
Automatic front opening and side opening for
easy access in case of maintenance.
Robot for quick and precise handling of the
pieces to be marked





WAMGROUP

WAM Industriale S.p.A. via Cavour 338 - Ponte Motta / Carezzo (MO) - IT

TYPE MTX52684957-0
Serial No. 20202406
2020



Kg. 852
3.5





1 marcatore fiber laser con lettore di codice data matrix, apertura automatica frontale e apertura laterale per accesso agevole alle regolazioni

1 fiber laser marker with data matrix code reader, automatic front opening and side opening for easy access to adjustments with rotating feeding table

Prima della marcatura la superficie viene "sbiancata" dal marcatore per consentire la verifica di leggibilità del codice, su materiali riflettenti

Before marking the surface is "bleached" by the marker to allow the code to be readable, on reflective materials

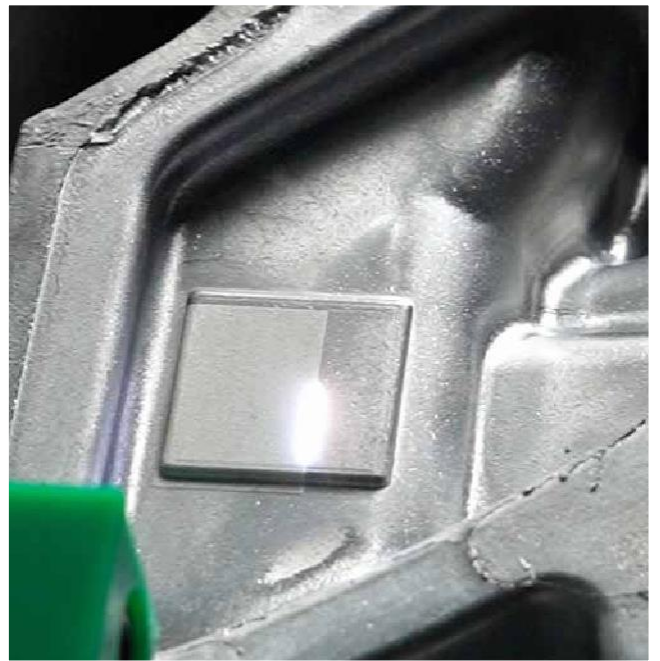

Sistema automatico per la marcatura laser di anime in cartone e PVC (o altri polimeri).
Completo di tavola rotante di caricamento e cadenziatore con marcatura a prodotto fermo (produttività 60pz/min)

*Automated laser marking system for cardboard and PVC cores (or other polymers).
Complete with rotating feeding table cadencer for marking with the products still (productivity 60 pces/min)*

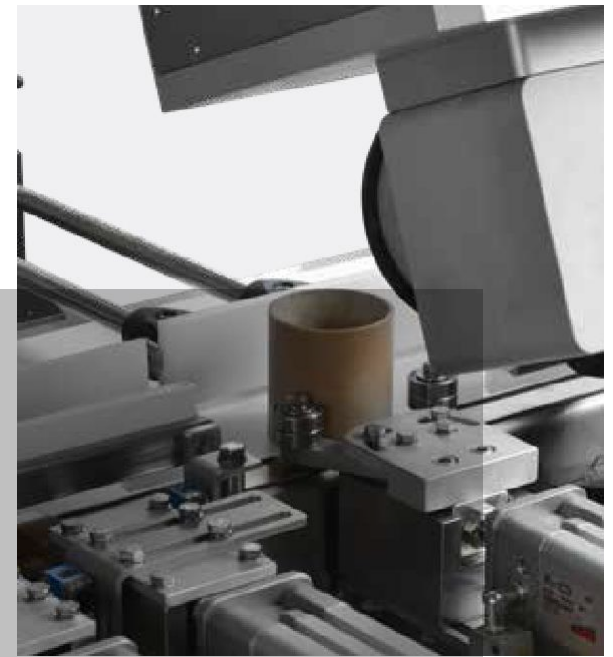



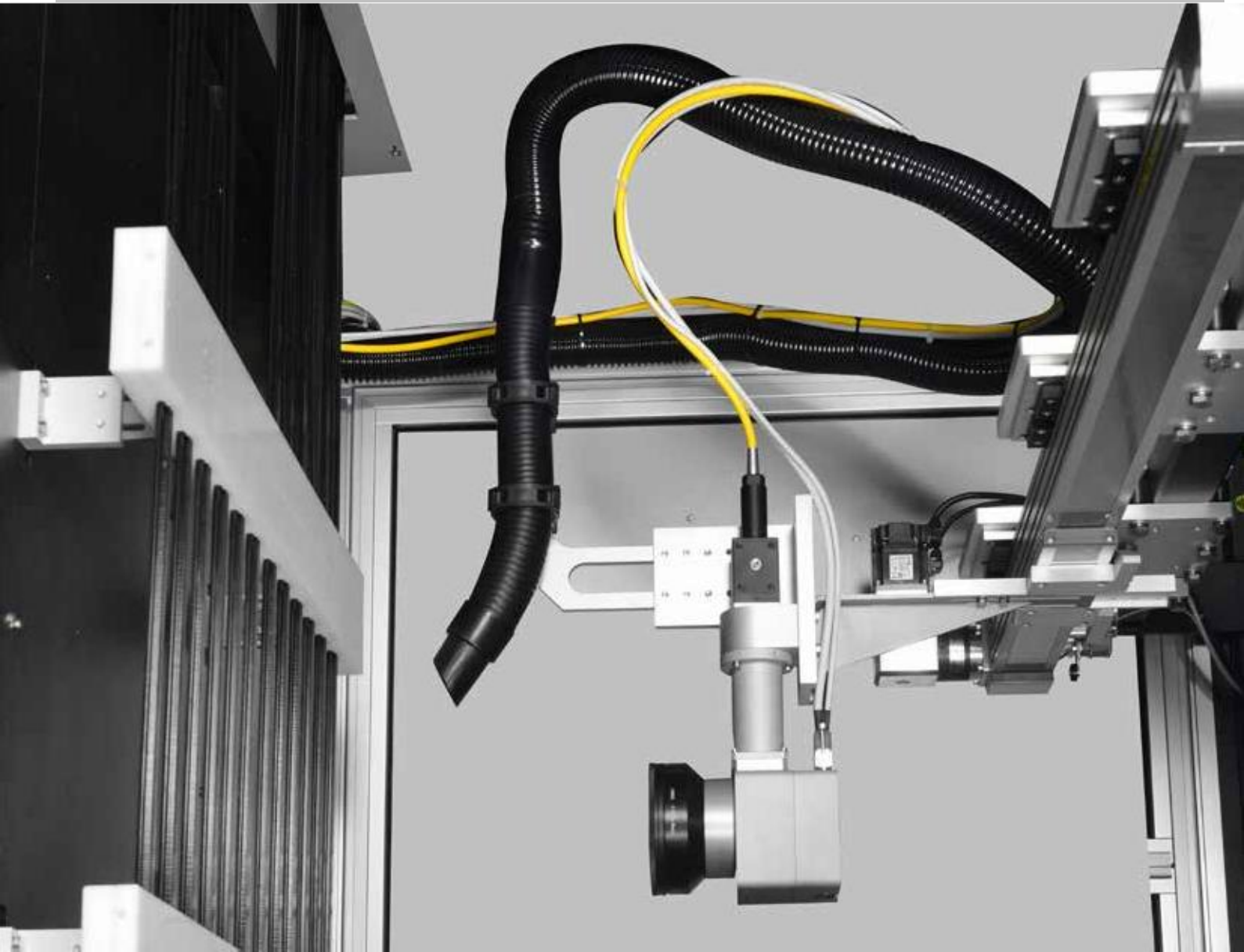

Marcatura su 24 prodotti affiancati in movimento
con traslazione trasversale automatica
del marcatore

*Marking on 24 moving products (side by side)
with automated transverse marker transfer*

I prodotti sono movimentati dalla linea del
cliente e guidati all'interno del sistema da
apposite dime a bassa aderenza

*The products are fed from the customer's line
and guided into the system by special
low-adherence templates*

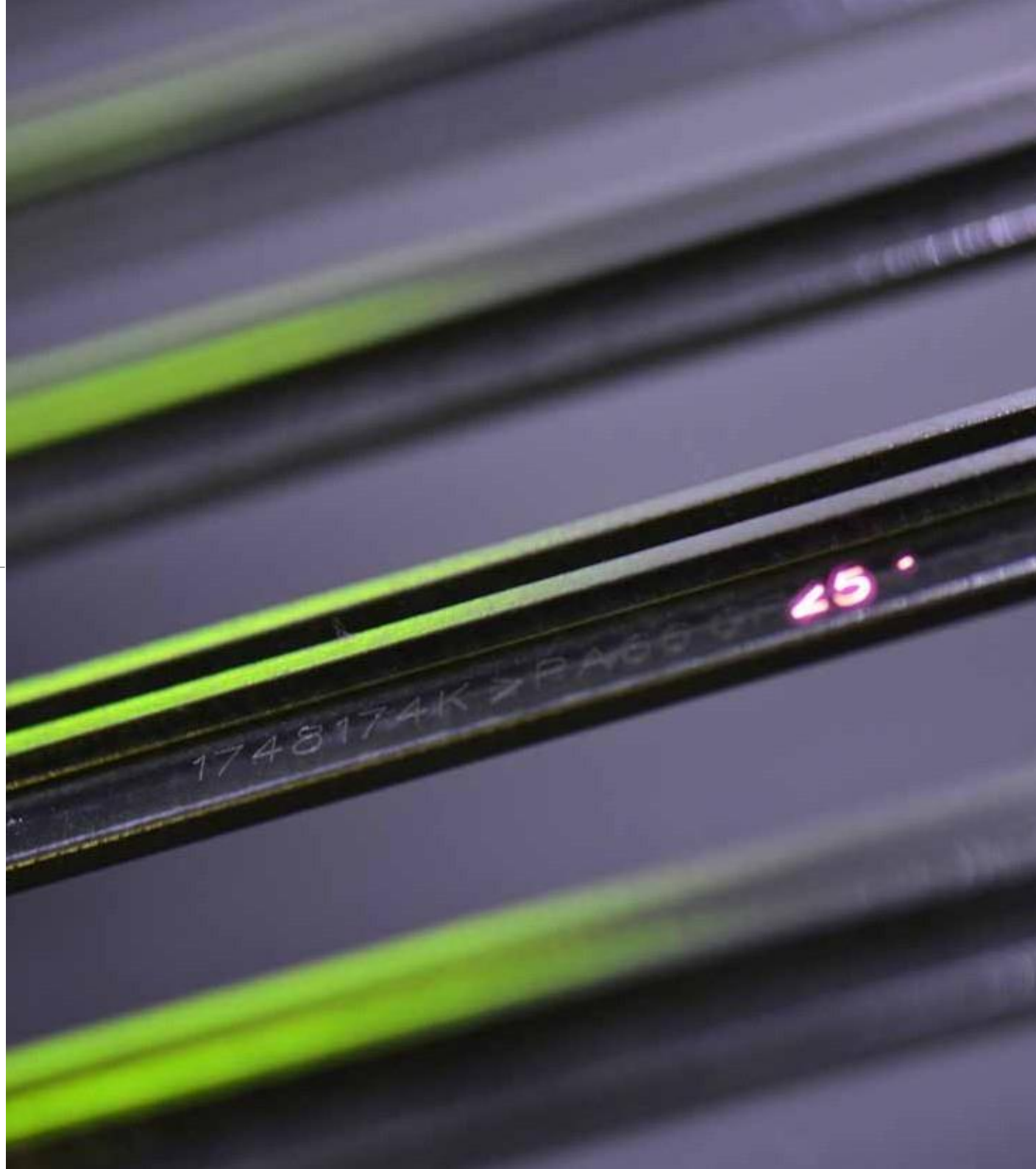

Sistema semiautomatico di marcatura fiber laser; effettua anche il test di funzionalità elettrica del prodotto e l'ispezione visiva di assemblaggio corretto: componenti esatti (con discriminazione di forma e colore) e in posizione idonea

Semi-automated fiber laser marking system; also performs a product electrical functionality test and correct assembly visual inspection: exact components (discriminating for shape and color) and correct position

Contenitore di sicurezza per prodotti difettosi con riconciliazione automatica controllata via software

Safety container for defective products, with automated reconciliation via software



Il pezzo da marcare viene posizionato manualmente. La chiusura automatica scorrevole include barriere di sicurezza fotoelettriche

Pieces to be marked are manually positioned. The sliding automated closing includes photoelectric safety barriers



Laser for **AUTOMOTIVE PLASTIC PARTS**



Marchatura senza dime Marking without templates



Sistema per la marcatura laser di prodotti con fogge e finiture differenti, senza necessità di dime di posizionamento. Integra un sistema di visione ad alta precisione che rileva ogni pezzo e la sua sagoma, posizionando automaticamente il marcatore alla corretta distanza focale

- integrazione 4.0 con il sistema informativo del cliente
- infinite possibilità di personalizzazione del dato anche ai fini della tracciabilità
- possibilità di caricamento simultaneo di più pezzi per ottimizzare la produzione
- caricamento facilitato mediante visualizzazione della sagoma dei prodotti sul piano di appoggio

System for laser marking of products with different shapes and finishes, without the need for positioning templates. It integrates a high-precision vision system that detects each piece and its shape, automatically positioning the marker at the correct focal distance

- 4.0 integration with the customer's information system
- endless possibilities of personalization of the data also for the purposes of traceability
- possibility of simultaneous loading of several pieces to optimize production
- facilitated loading by viewing the shape of the products on the support surface

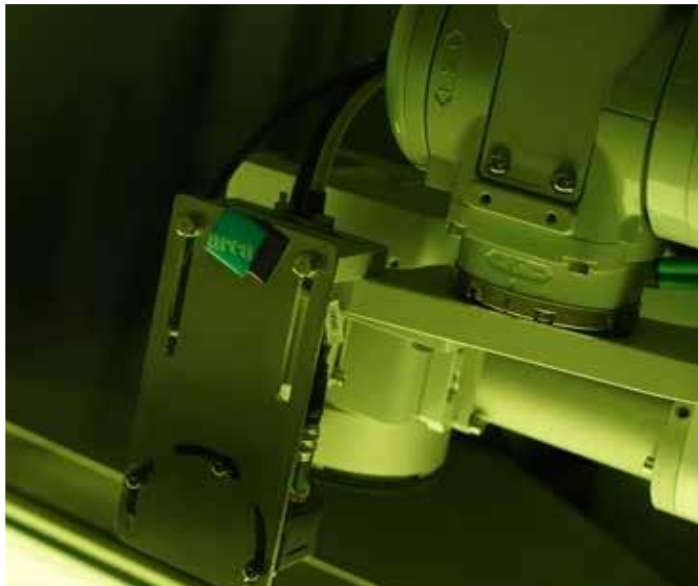

Marcatura senza dime Marking without templates

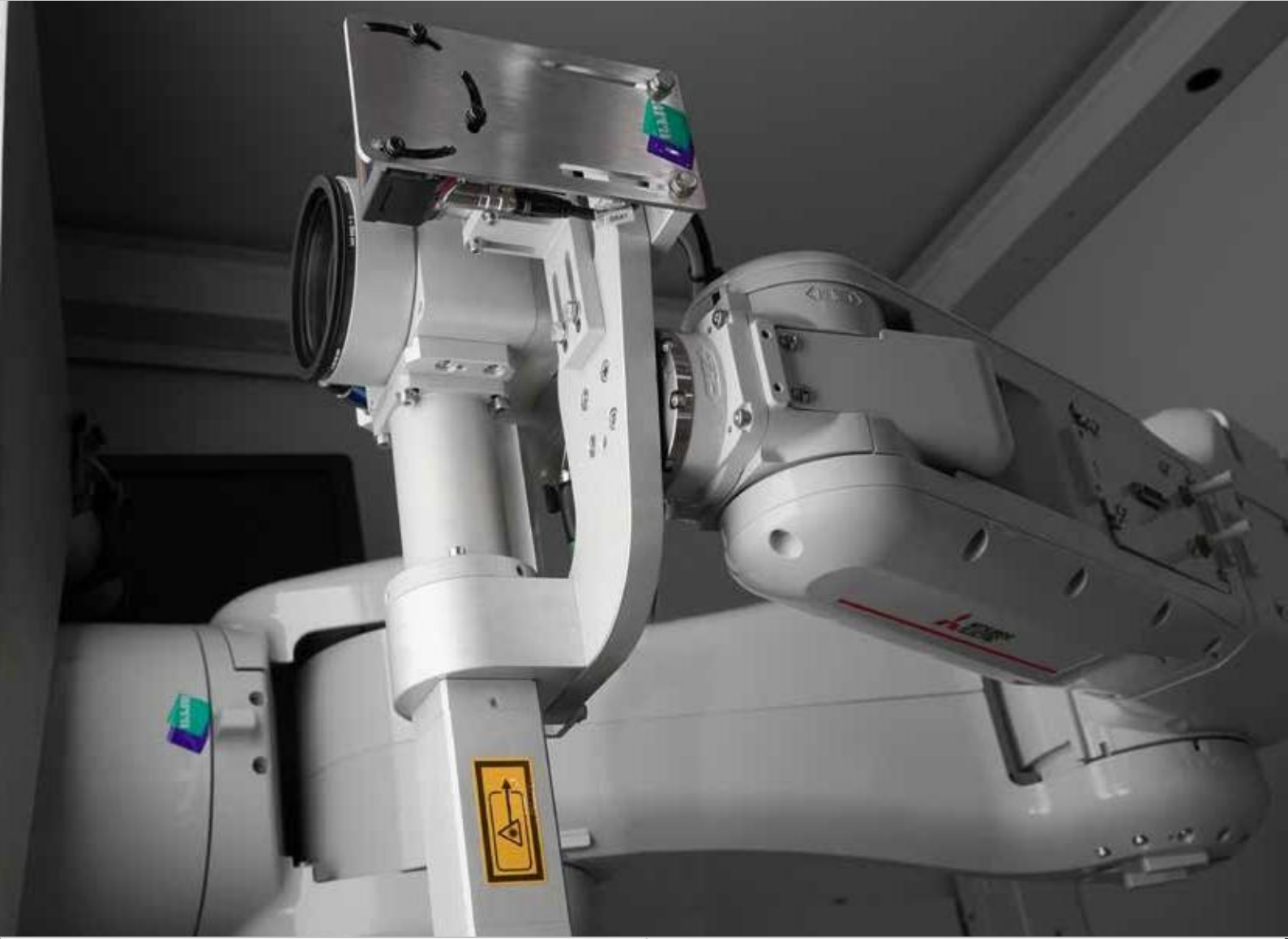



Le stazioni di marcatura Arca sono integrabili con altre macchine di processo. Ad esempio, macchine di stampa tampografica per la colorazione delle superfici pretrattate laser.

I pezzi sono portati automaticamente all'interno della stazione di marcatura dalla movimentazione della macchina tampografica

The Arca marking stations can be integrated with other process machines. For example, pad printing machines for coloring laser pretreated surfaces.

The pieces are automatically brought inside the marking station by the movement of the pad printing machine







Regolazione
verticale automatica

*Automatic vertical
adjustment*





ALTEA

MIB A
CVP
DEL DOPPIO VITIGNARI





FIBRAPAN	2850X2100X22	18.079.13.01
FIBRAPAN	2850X2100X22	18.079.13.01
FIBRAPAN	2850X2100X22	18.079.13.01
FIBRAPAN	2850X2100X22	18.079.13.01
FIBRAPAN	2850X2100X22	18.079.13.01
FIBRAPAN	2850X2100X22	18.079.13.01
FIBRAPAN	2850X2100X22	18.079.13.02
FIBRAPAN	2850X2100X22	18.079.13.02
FIBRAPAN	2850X2100X22	18.079.13.02
FIBRAPAN	2850X2100X22	18.079.13.02
FIBRAPAN	2850X2100X22	18.079.13.02
FIBRAPAN	2850X2100X22	18.079.13.02
FIBRAPAN	2850X2100X22	18.079.13.02
FIBRAPAN	2850X2100X22	18.079.13.02
FIBRAPAN	2850X2100X22	18.079.13.02
FIBRAPAN	2850X2100X22	18.079.13.02

La struttura di sostegno Side può essere cabinata con una pannellatura protettiva (completa di aspiratore), per proteggere gli operatori e il marcatore laser dalla polvere. La regolazione di posizione sull'asse verticale è automatica e controllata via software

The Side support structure can be cabined with a protective paneling (including extractor fan), to protect operators and the laser marker from dust. Position adjustment on vertical axis is automatic and controlled by software

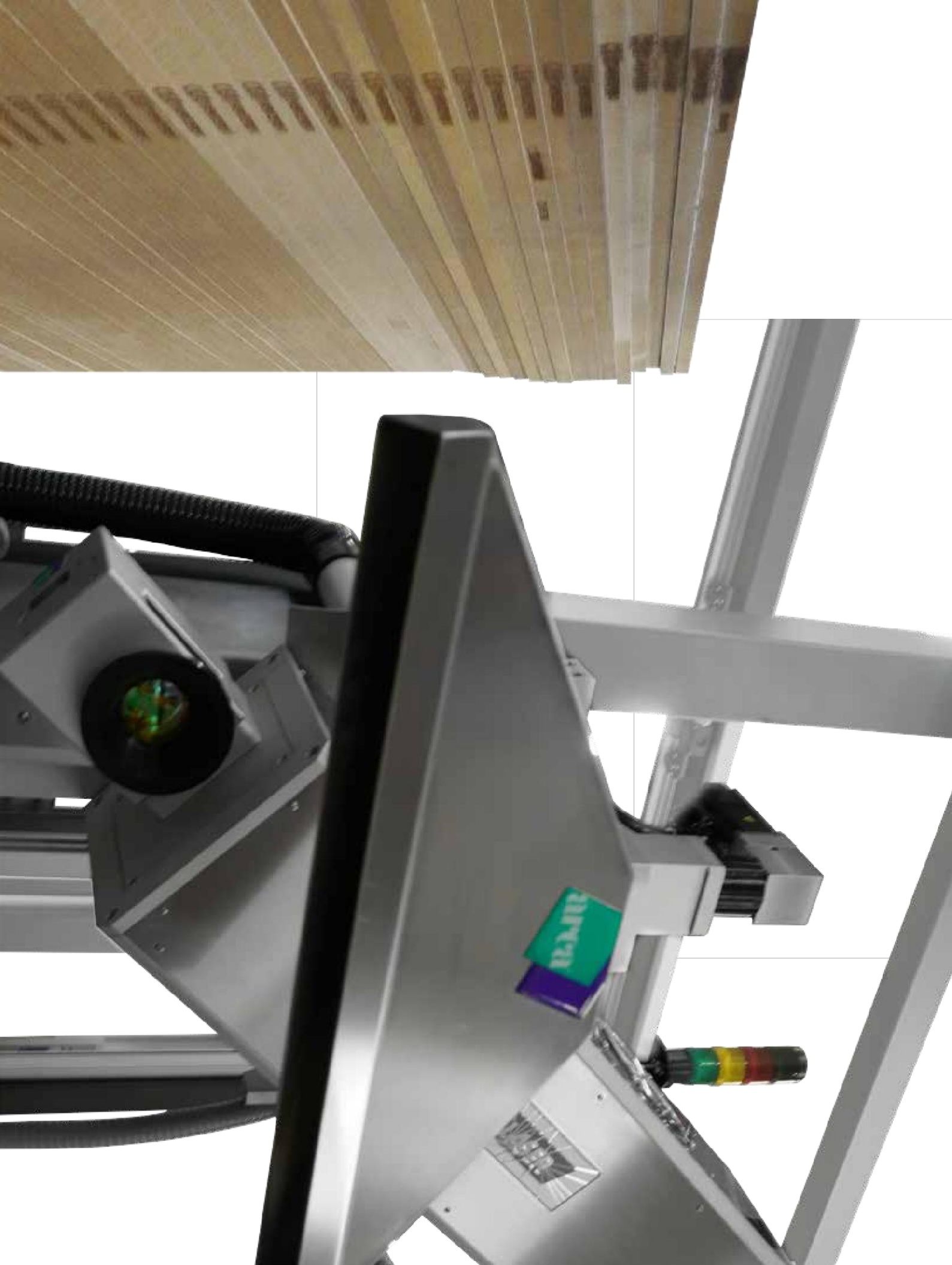

I marcatori laser rappresentano lo strumento più moderno ed efficace per la personalizzazione delle etichette autoadesive (stampa di dati variabili come testi alfanumerici, loghi e codici 1D/2D).

Garantiscono una serie di importanti vantaggi rispetto a tutti gli altri sistemi di stampa:

- nessun materiale di consumo da pagare, ordinare gestire a stock
- funzionamento “non stop”: nessun tempo morto (arresto linea) per rifornimento del materiale di consumo
- nessuno scarto da smaltire: nessun supporto del nastro TT o cartucce vuote dell'inchiostro

- rendimento del 99,9%: nessun organo in movimento soggetto a usura, nessuna testina danneggiata/dot bruciato, nessun ugello intasato o nastro TT difettoso

- punto di marcatura sull'etichetta definito via software, senza nessuna regolazione meccanica

e, ove il marcatore sia collocato direttamente sullo staccatore:

- funzione print apply: ultima etichetta stampata, prima applicata, senza “coda” di etichette già personalizzate
- nessun rinvio che complica il percorso della banda

Marcatori laser Fiber e CO₂ per la personalizzazione di etichette

Fiber and CO₂ laser markers for labels personalization

“Laser markers are the most advanced and effective tool for customizing self-adhesive labels (printing of variable data such as alphanumeric texts, logos and 1D/2D codes), guaranteeing a wide range of essential benefits compared to all other printing systems:

- *no consumable materials to pay for, order and manage in stock*
- *“non stop” operation: no downtime (line stoppage) for replenishing consumable materials*
- *no discarded waste to manage: no TT ribbon liner or empty ink cartridges*

- *99.9% production yield: no moving parts subject to wear, no damaged print head /burnt dots, no clogged nozzles or defective TT ribbons*

- *label marking point defined via software, no mechanical adjustment needed,*

and, where the marker is positioned directly on the peeler:

- *print apply function: last printed label, first label applied, no pre-customized label “queue”*
- *no delay complicating the ribbon path*

Personalizza le tue etichette auto-adesive Customize your self-adhesive labels



I marcatori laser Arca stampano su etichette:
- in nero, su carta speciale bianca sensibile al laser
- in nero su qualsiasi materiale trattato con apposite vernici
- in negativo su un fondo di colore scuro

*“Arca laser markers print onto labels:
- in black, on special white laser sensitive paper
- in black, on any material treated with special paints
- in negative on a dark colored background”*

Personalizza le tue etichette auto-adesive Customize your self-adhesive labels

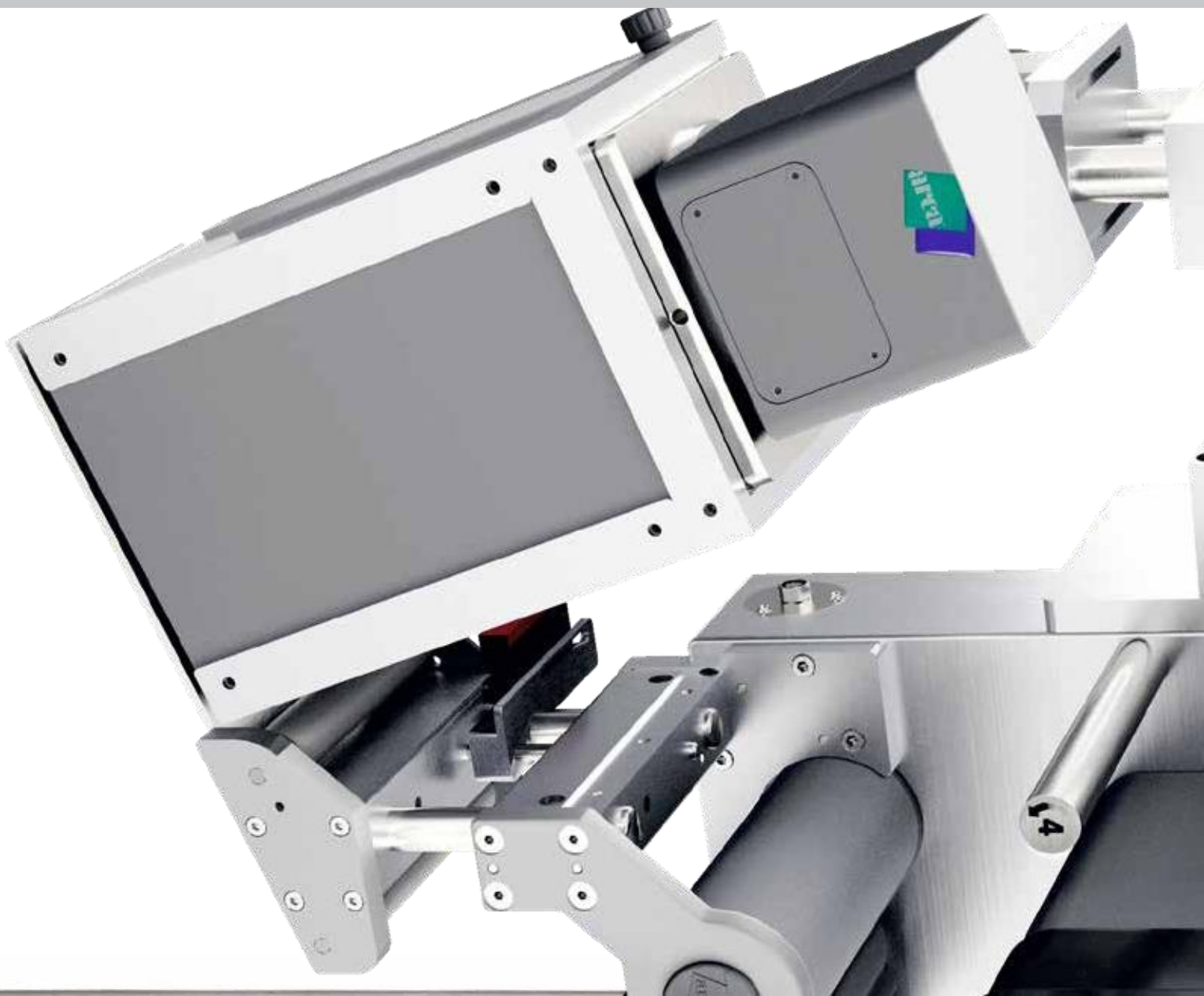

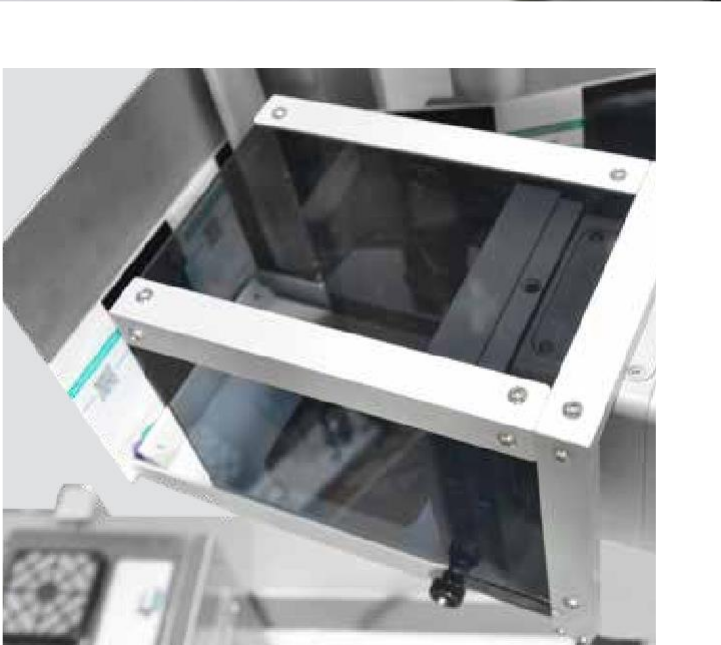

Fabbrica le tue etichette in fogli Manufacture your sheet labels



Sistema per la produzione di etichette auto-adesive, confezionate in fogli, mediante fustellatura e marcatura laser; tipicamente utilizzate nel settore automotive e ove conveniente l'applicazione manuale.
Impiega materiali standard o, durevoli, sensibili al laser

- integrazione 4.0 con il sistema informativo del cliente
- sequenza stampa-prelievo controllata
- infinite possibilità di personalizzazione del dato e della sagoma di ciascuna etichetta
- sistema di trazione e taglio brevettato per neutralizzare gli effetti dell'adesivo (sporczia e inceppamenti)

System for the production of self-adhesive labels packaged in sheets, by laser die-cutting and marking; typically used in the automotive sector and where convenient manual application

Uses standard or, durable, laser sensitive materials.

- 4.0 integration with the customer's information system
- controlled print-picking sequence
- endless possibilities for customizing the data and the shape of each label
- traction and patented cutting system to neutralize the effects of the adhesive (dirt and jams)

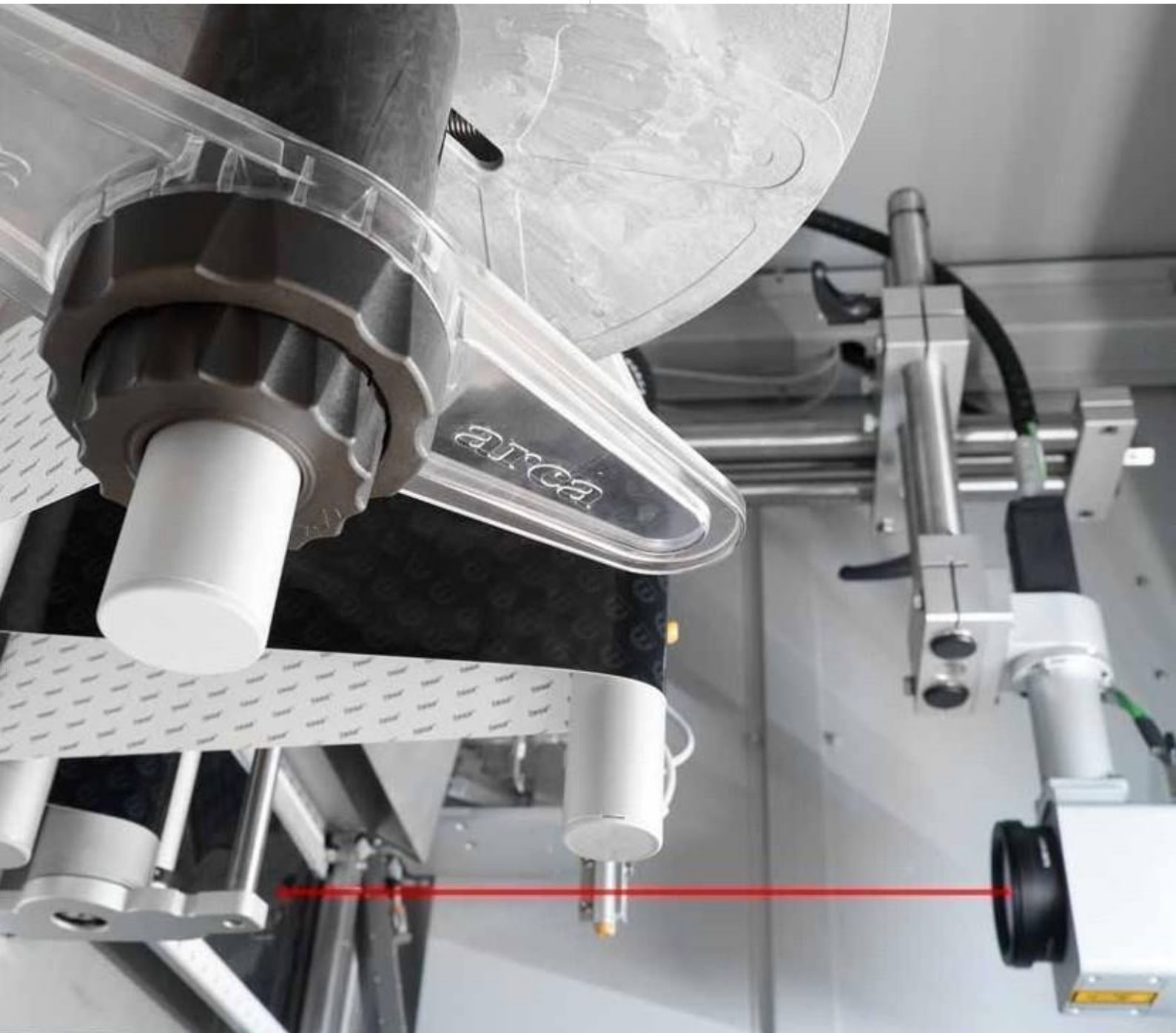

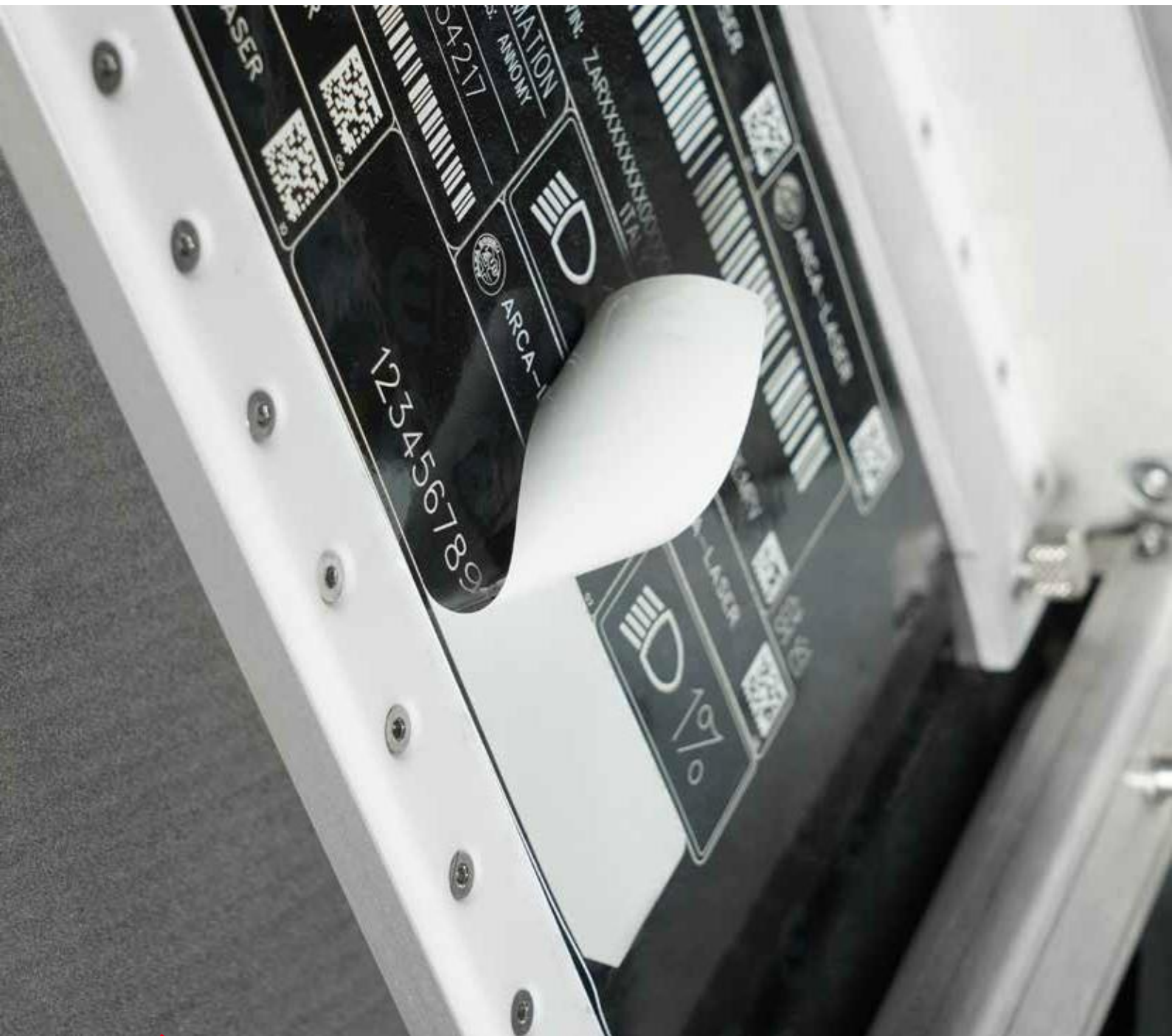

La pulsantiera indipendente è posizionabile ove più pratico per l'operatore e rappresenta una valida soluzione operativa, indispensabile quando la marcatura laser sia effettuata "fuori linea"

L'interfaccia operatore e la gestione della grafica può avvantaggiarsi di un'interfaccia touch screen, a colori, di ultima generazione; idonea alla gestione di qualsiasi applicativo per la marcatura e la tracciabilità



An independent control keypad can be positioned where it is most practical for the operator; a valid operating solution that is indispensable when performing laser marking "off line"

The operator interface and graphics management can make use of an advanced color touch screen interface; suitable for managing any marking and traceability applications



I fumi potenzialmente generati dalla marcatura laser sulla maggior parte dei materiali, devono essere filtrati. L'impiego di appositi aspiratori consente di evitare ogni emissione nociva.

Arca dispone di un'ampia gamma di aspiratori ad alte prestazioni, studiati per l'uso con marcatori laser e destinati all'impiego in ambiente industriale.



Fumes potentially generated by the laser marking process on the majority of materials must be filtered. Special suction devices prevent harmful emissions. Arca offers a wide range of high performance suction devices, specially designed to be used with laser markers, and built for industrial environments



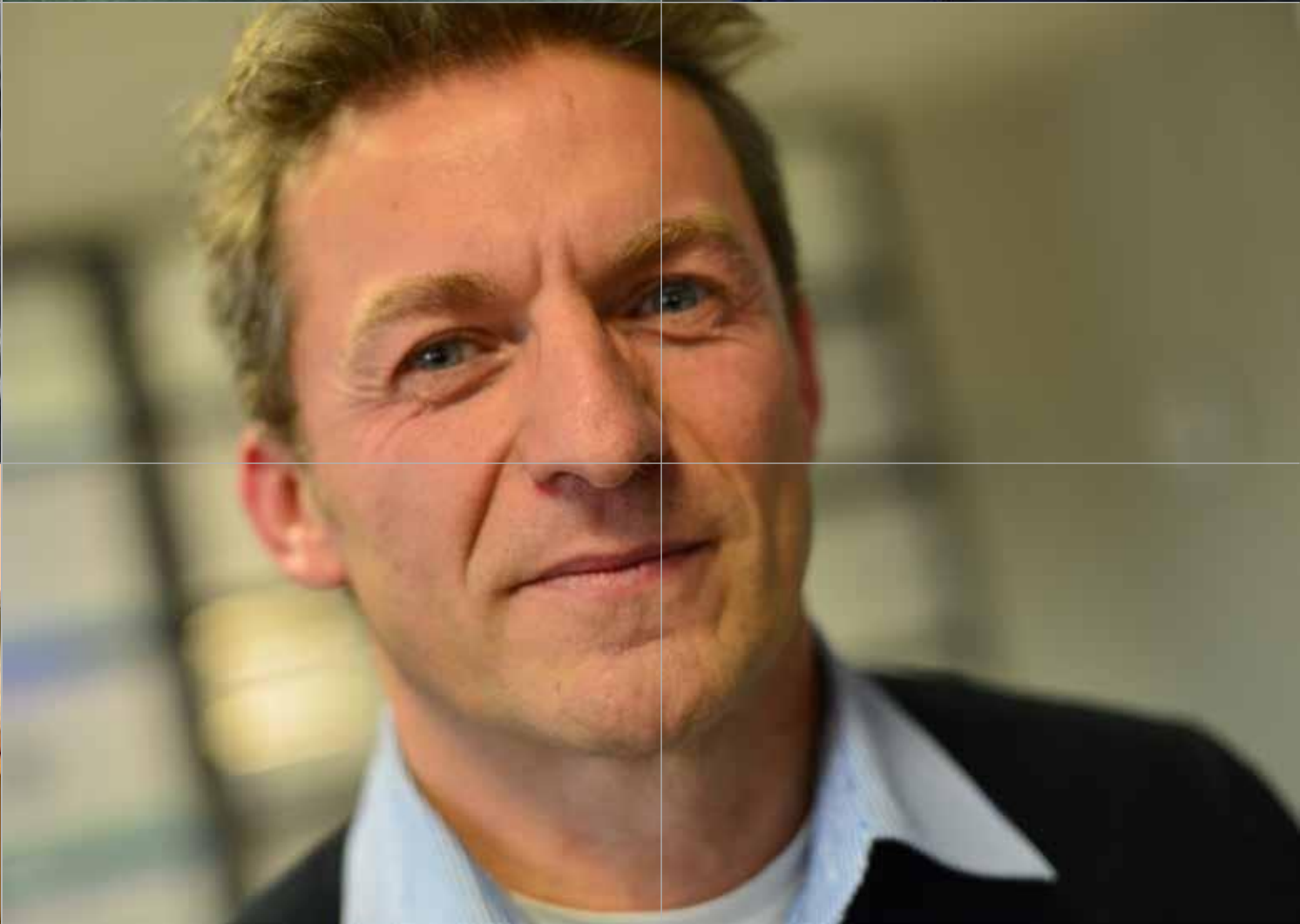











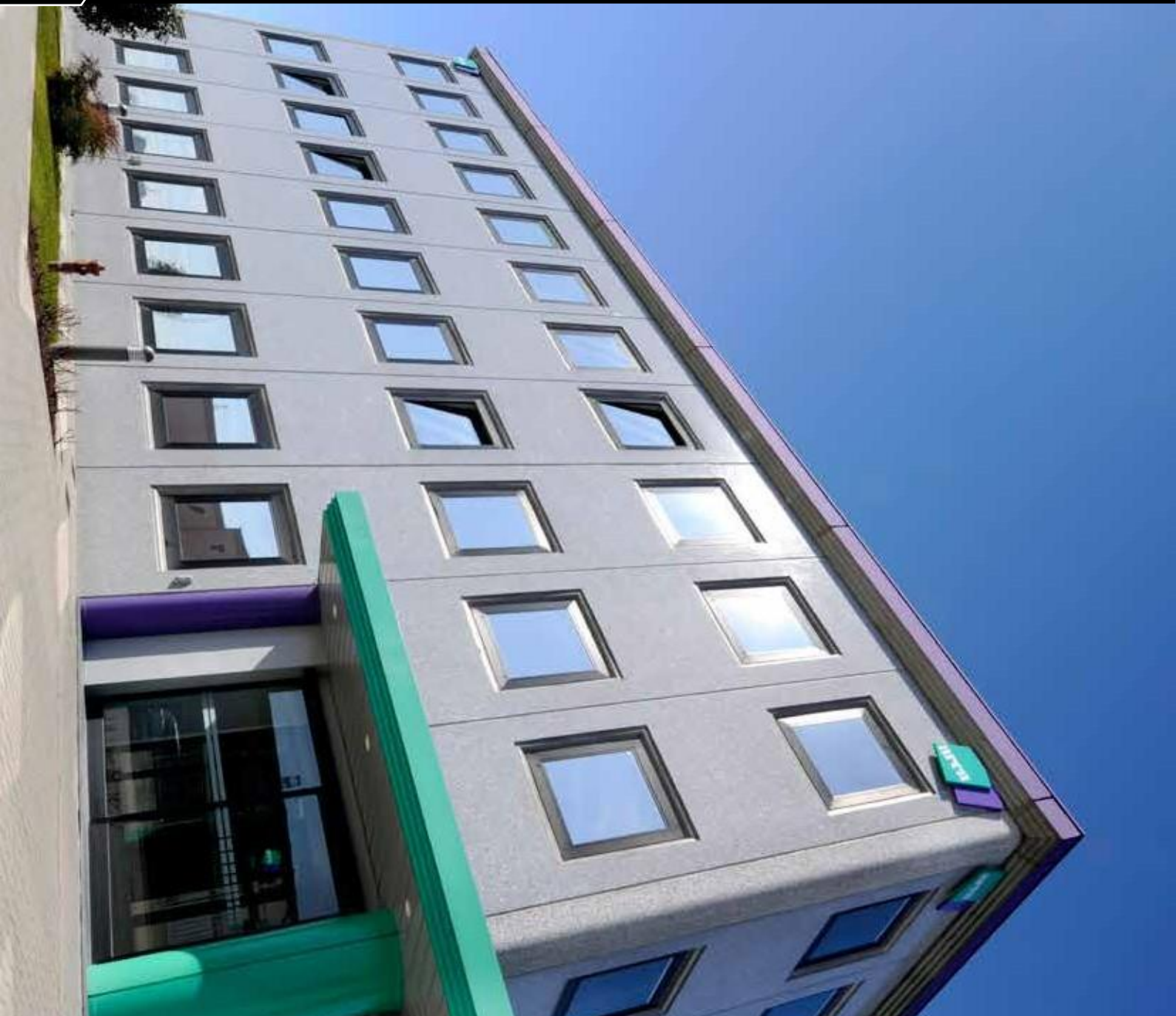







Magazzino automatico verticale, connesso al sistema informativo per la selezione dei componenti guidato dalla "distinta base" degli articoli da prodursi. Riduce i tempi di prelievo e gli eventuali errori

Automatic vertical warehouse, connected to the information system for the selection of components guided by the "bill of material" of the articles to be produced. It reduces picking time and any mistakes



Le immagini rappresentate in questa pubblicazione sono da considerarsi puramente indicative

I dispositivi illustrati possono essere forniti, di serie o come opzionali, per tutte o solo per parte delle etichettatrici. Per verificare la specifica dotazione di ciascun modello fare riferimento alle tabelle riassuntive

Arca si riserva la facoltà di apportare, senza preavviso, cambiamenti della dotazione di serie e modifiche costruttive alle macchine che possano comportare variazioni delle caratteristiche e delle prestazioni qui indicate. Per verificare l'attualità delle informazioni riportate nella presente pubblicazione, è necessario consultare il listino prezzi Arca in vigore

In questa pubblicazione sono rappresentati prodotti marcati da Arca. L'eventuale riproduzione di prodotti di terzi, identificati dal rispettivo marchio, avviene al solo ed unico scopo di mostrare le caratteristiche tecniche dei nostri prodotti o dell'applicazione

I nomi propri utilizzati nella pubblicazione sono marchi di fatto oggettivamente riconducibili alla titolarità di Arca Etichette, su base documentale. E' fatto espresso divieto a terzi, di uso o riproduzione con qualsiasi mezzo

Eventuali marchi di terzi sono impiegati al solo scopo di identificare componenti o dispositivi integrati nei sistemi Arca

ARCA ETICHETTE SPA 20010 MARCALLO (MI) - ITALY
VIA EDISON, 119 - tel. +39 02 97231.1 - fax +39 02 9761633

www.arcalabelingmarking.com

Disclaimer



The pictures shown in this publication are purely indicative

The illustrated devices can be supplied, serial or as optionals, for all or only for a part of the labelers. To check the specific equipment of each model, please refer to the summary tables

Arca reserve the right to make, without prior warning, changes to the series equipment and machine construction modifications which may bring about variations to the features and performance indicated here. To check the validity of the information contained in this publication, please consult the prevailing Arca pricelist

This publication shows products marked by Arca. Any reproduction of third party products, identified by their respective brand, takes place solely and uniquely with the aim of showing the technical features of our products or of the application

The proper nouns used in this document are virtual trademarks objectively attributable to the property of Arca Etichette on a documental basis.

The use or reproduction by any means of the above mentioned trademarks by third parties is explicitly forbidden

Possible third parties brands are used with the only purpose to identify components or devices embedded in the Arca's systems

Made in **ITALY**



SMART
CODING & LABELING

Commutator (55) 55 87 96 34 ext. 1010

- atencionalcliente@smarttcoding.com (55)18563081
- ventas@smarttcoding.com (55) 63475547
- serviciotecnico@smarttcoding.com (55) 63479110